

EcoPump AD

Air Operated Diaphragm Pump

Operation manual

MPU00010EN, V05

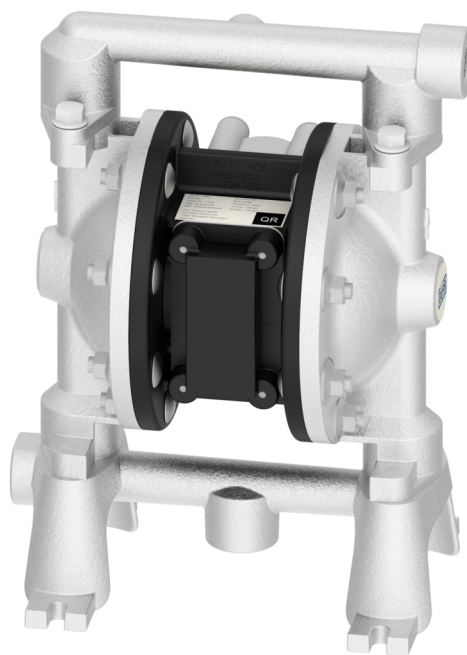
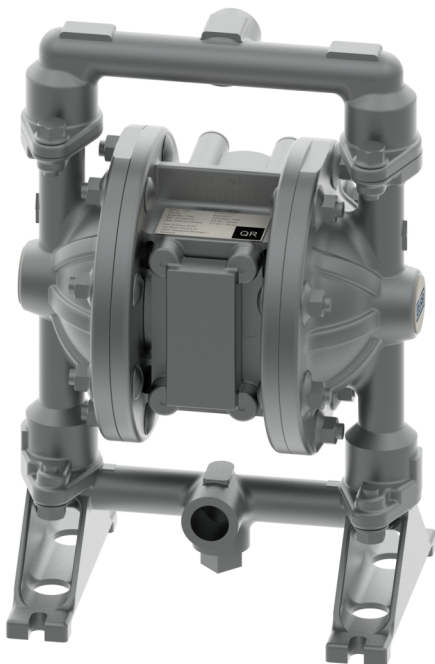

Dürr Systems AG
Application Technology
Carl-Benz-Str. 34
74321 Bietigheim-Bissingen
Germany
Telefon: +49 (0)7142 78-0
Internet: www.durr.com

Translation of the original operation manual

MPU00010EN, V05

Weitergabe und Vervielfältigung dieses Dokuments sowie Verwertung und Mitteilung seines Inhalts sind nicht gestattet, soweit nicht ausdrücklich zugestanden. Zuwiderhandlungen verpflichten zu Schadenersatz. Alle Rechte für den Fall der Patenterteilung oder Gebrauchsmuster-Eintragung vorbehalten.

© Dürr Systems AG 2015



Information about the document

This document describes the correct handling of the product.

- » Read the document prior to every activity.
- » Prepare the document for the application.
- » Pass on the product only together with the complete documentation.
- » Always follow safety instructions, handling instructions and specifications of every kind.
- » Illustrations can deviate from the technical construction.

Validity range of the document

The scope of the document is as follows:

N24140007 EcoPump AD 150 7 SST 1/2"	
N24140009 EcoPump AD 150 7 ALU 1/2"	

Hotline and Contact

If you have queries or would like technical information, please contact your dealer or sales partner.

TABLE OF CONTENTS

1	Product overview	5	9.3.1	General notes.....	19
	1.1 Overview.....	5	9.3.2	Dismantle inlet and outlet mani- fold.....	20
	1.2 Short description.....	5	9.3.3	Dismantle material assembly.....	20
2	Safety	5	9.3.4	Dismantle pneumatic assembly.....	21
	2.1 Presentation of Notes.....	5	9.3.5	Assemble pneumatic assembly.....	22
	2.2 Intended Use.....	6	9.3.6	Assemble material assembly.....	23
	2.3 Residual risks.....	6	9.3.7	Assemble inlet and outlet mani- folds.....	23
	2.4 Conduct in the event of a hazardous situation.....	7	10	Faults	25
	2.5 Staff qualification.....	7	10.1	Defects table.....	25
	2.6 Personal protective equipment.....	7	11	Disassembly and Disposal	28
3	Design and Function	8	11.1	Disassembly.....	28
	3.1 Design.....	8	11.2	Disposal	30
	3.2 Operation.....	10	12	Technical data	31
4	Transport, scope of supply and storage	10	12.1	Dimensions and weight.....	31
	4.1 Transport.....	10	12.2	Connections.....	31
	4.2 Unpacking.....	10	12.3	Operating conditions.....	31
	4.3 Scope of delivery.....	11	12.4	Operating values.....	31
	4.4 Storage.....	11	12.5	Compressed air quality.....	31
5	Assembly	11	12.6	Type plate.....	32
	5.1 Requirements for the Installation point.....	11	12.7	Operating and auxiliary materials....	32
	5.2 Assembly.....	11	12.8	Materials used.....	33
	5.3 Assembling ground conductor.....	12	12.9	Tightening torques.....	33
	5.4 Connecting.....	13	12.10	Characteristic curve of the outflow rate.....	33
6	Commissioning	15	13	Replacement parts, tools and accesso- ries	33
	6.1 Safety recommendations.....	15	13.1	Replacement parts.....	33
	6.2 Preparing for commissioning.....	16	13.2	Tools.....	34
	6.3 Setting operating parameters	16	13.3	Accessories.....	34
7	Operation	16	13.4	Order.....	34
	7.1 Safety recommendations.....	16	14	Index	36
	7.2 General notes.....	17			
	7.3 Starting Operations.....	17			
	7.4 Rinsing.....	17			
	7.4.1 Safety recommendations.....	17			
	7.4.2 Flush the pump.....	17			
8	Cleaning	18			
	8.1 Safety recommendations	18			
	8.2 Cleaning.....	18			
9	Maintenance	18			
	9.1 Safety recommendations.....	18			
	9.2 Maintenance schedule.....	19			
	9.3 Dismantle and assemble.....	19			

1 Product overview

1.1 Overview

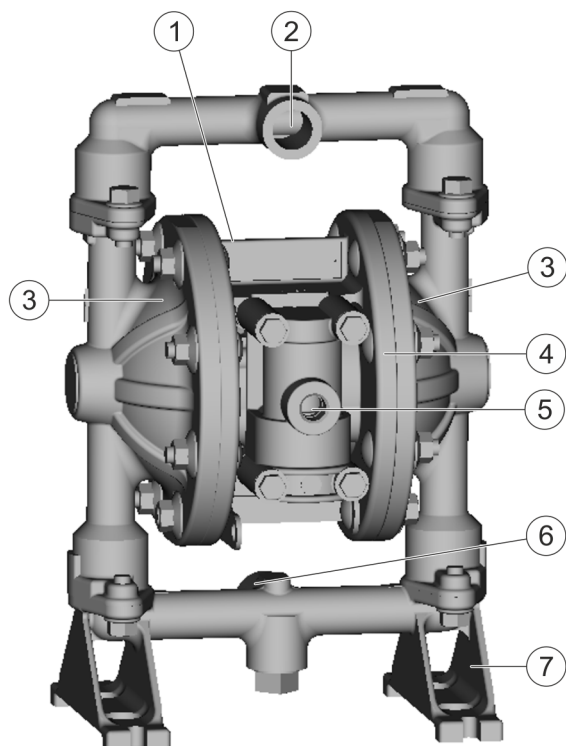

Fig. 1: Overview, N24140007

- 1 Type plate (back)
- 2 Pressure side connection for material supply
- 3 Material assembly
- 4 Pneumatic assembly
- 5 Compressed air connection
- 6 Suction side connection for material supply
- 7 Mounting feet

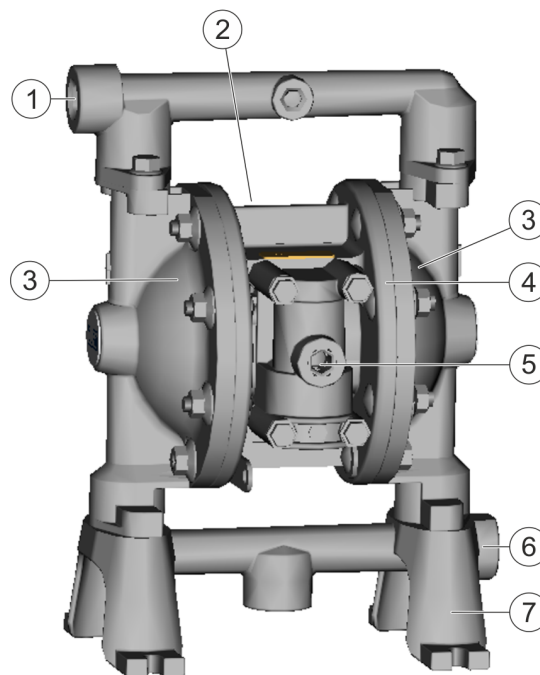

Fig. 2: Overview, N24140009

- 1 Pressure side connection for material supply
- 2 Type plate (back)
- 3 Material assembly
- 4 Pneumatic assembly
- 5 Compressed air connection
- 6 Suction side connection for material supply
- 7 Mounting feet

1.2 Short description

The double diaphragm pump with pneumatic actuator (from here on "pump") is an air operated positive displacement pump. The pump is used to pump low- to medium-viscosity liquids (flammable and non-flammable coating materials) in industrial coating of surfaces.

2 Safety

2.1 Presentation of Notes

The following notes can appear in this instruction:

DANGER!

High risk situation that can lead to serious injuries or death.



WARNING!

Medium risk situation that can lead to serious injuries or death.



CAUTION!

Low risk situations that can lead to minor injuries.



NOTICE!

Situations that can lead to material damage.



ENVIRONMENT!

Situations that can lead to environmental damage.



Additional information and recommendations.

2.2 Intended Use

Use

The **EcoPump AD** is solely intended for pumping low- to medium-viscosity fluids of the fluid group 1 according to the Pressure Devices Directive.

The **EcoPump AD** is intended for use in industry and trade only.

The **EcoPump AD** may be used under the following conditions:

- » in explosive areas of Ex zones 1 and 2
- » in non-explosive areas
- » with flammable fluid coating materials of the Explosion group IIA
- » with non-flammable fluid coating materials

Only use the pump within the approved operating conditions ↪ 12 “Technical data”.

Misuse

If used improperly, it can cause serious injuries.

Examples of wrong use are:

- » Use in areas with Ex zone 0
- » Use of unapproved materials, see safety data sheets
- » Making conversions or changes on your own
- » Use of pumps as a support for the pipe system

Ex labeling

II 2G Ex h IIA T6 Gb X

- II - Device group II: all areas except mining
- 2G - Device category 2 for gaseous ex-atmosphere

Ex h - Ignition protection category for non-electrical devices

IIA - Explosion group

T6 - Temperature class

Gb - Device protection level: Zone 1

X - Restriction: The device is configured for operation in an ambient temperature of 15°C to 40°C.

2.3 Residual risks

Explosion danger

Pumps with aluminum parts in contact with media may not be used with 1,1,1-trichloroethan, methylene chloride or other hydrocarbon-solvents containing halogen. Reaction and explosion of these materials can cause serious injury or death. Reaction and explosion of these materials can cause serious injury or death.

- » Pump motor section
- » Fluid caps
- » Distributor
- » Parts in contact with material

Explosion danger

Pumps with conductive Acetal parts in contact with media may not be used with acids and lyes. Reaction and explosion of these materials can cause serious injury or death. Reaction and explosion of these materials can cause serious injury or death.

- » Pump motor section
- » Fluid caps
- » Distributor
- » Parts in contact with material

Sparks due to electrostatic discharge

If die Pumpe is not properly grounded or the potential equalization fails, components may get charged electrostatically. Electrostatic discharge can cause sparks that in explosive atmosphere can cause a fire or an explosion. Serious injury and death could be the consequence.

- » Ground Pumpe as specified.
- » Check connection of grounding cable during operation.
- » Measure volume resistivity.

Media

Material escaping under pressure can cause serious injuries.

Before working on the product:

- » Disconnect the system, in which the product is installed, from compressed air and material supply.
- » Depressurize the lines.
- » Secure the system against being switched on again.
- » Observe approved operating pressures ↪ 12.4 “Operating values”.

2.4 Conduct in the event of a hazardous situation

Conduct in case of danger depends on the operator's installation situation.

Perform the following activities:

- » Close lines.
- » Secure against reconnection.
- » Depressurize lines.

2.5 Staff qualification



WARNING!

Inadequate qualification

Wrong estimation of dangers can cause serious injury or death.

- Only sufficiently qualified persons may execute all work.
- Some work requires additional qualification. Additional qualifications of specialized personnel are marked with a “+”.

This document is intended for qualified personnel in industry and craftsmanship.

Cleaning staff

The cleaning staff receives regular instructions from the operator about the following contents:

- » Using the product
- » Handling cleaning tools
- » Handling cleaning agents
- » Technical Measures for occupational safety and health

Electrician

Electricians assemble, install, service and repair electrical systems in a professional manner.

Furthermore, electrical engineers have the following knowledge:

- » Guidelines, Standards and Rules of Engineering
- » Local conditions
- » Electrical Systems and Their Loading Limits
- » Technical Measures for occupational safety and health

Mechanic

The mechanic is trained specifically for the field of work in which he works.

Furthermore, he has the following knowledge:

- » Guidelines, Standards and Rules of Engineering
- » Local conditions
- » Technical Measures for occupational safety and health

The mechanic is responsible for the following activities on equipment and components:

- » Assembly
- » Waiting
- » Maintenance
- » Disassembly

+ additional qualification explosion protection

In addition to the knowledge of the various specialist fields, the mechanic has knowledge of regulations and safety measures when working in potentially explosive areas.

Dürr Systems offers special product training for ↪ “Hotline and Contact”.

2.6 Personal protective equipment

When working in explosive areas, the protective clothing, including gloves, must meet the requirements of DIN EN 1149-5. Footwear must meet the requirements of EN ISO 20344 and EN IEC 61340-4-3. The volume resistivity must not exceed 100MΩ.

Wear the specified personal protective equipment when working. Provide the following personal protective equipment:



Anti-Static Safety Boots

Protect feet from crushing, falling items and slipping on slippery ground.

Moreover, anti-static safety boots reduce electrostatic charge by discharging the electrostatic charges.



Eye protection

Protects eyes from dust, paint drops and particles.



Protective gloves

Protect the hands from:

- » mechanical forces
- » Thermal forces
- » Chemical effects



Protective workwear

Tight fitting workwear with low tear strength, tight sleeves and no hanging parts.



Respirator mask

Protects from hazardous gases, vapors, dust and similar materials and media.



Use ear protection

Protects from auditory damage due to noise.

3 Design and Function

3.1 Design

EcoPump AD main assemblies:

- » Pneumatic assembly (compressed air)
- » Material assembly
- » Inlet and outlet manifold

Pneumatic assembly (compressed air)

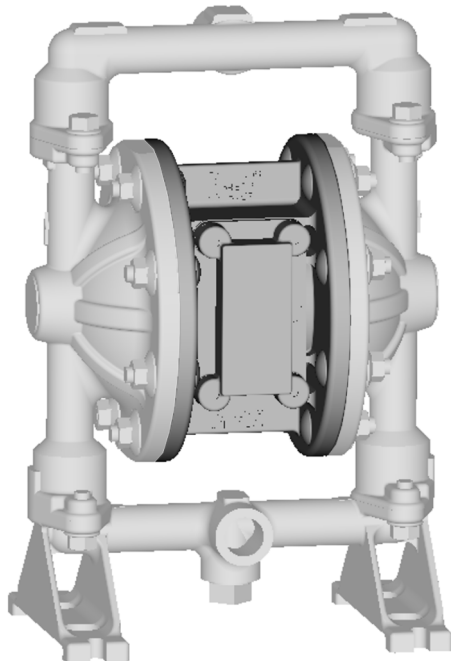

Fig. 3: Pneumatic assembly - Front view, N24140007

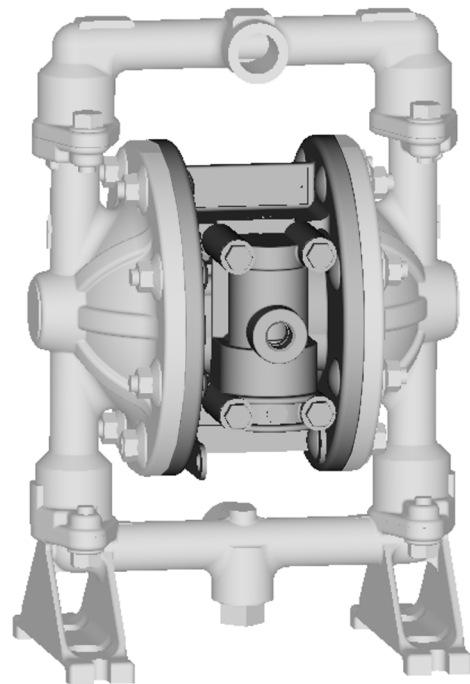

Fig. 4: Pneumatic assembly - Rear view, N24140007

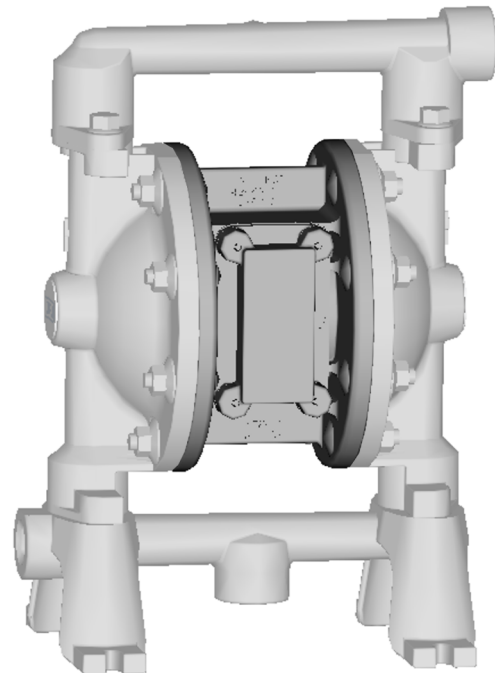

Fig. 5: Pneumatic assembly - Front view, N24140009

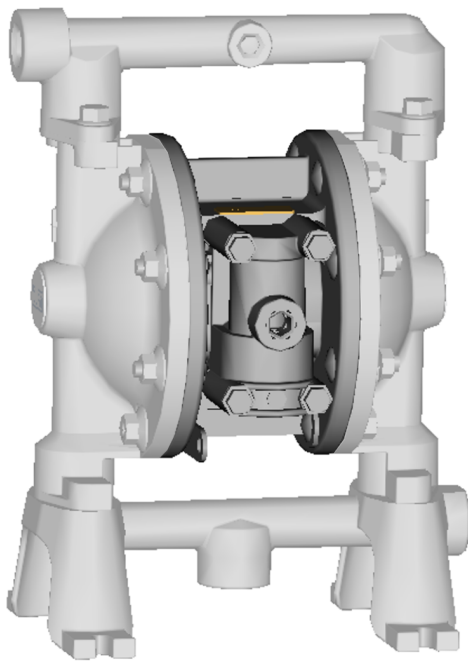

Fig. 6: Pneumatic assembly - Rear view, N24140009

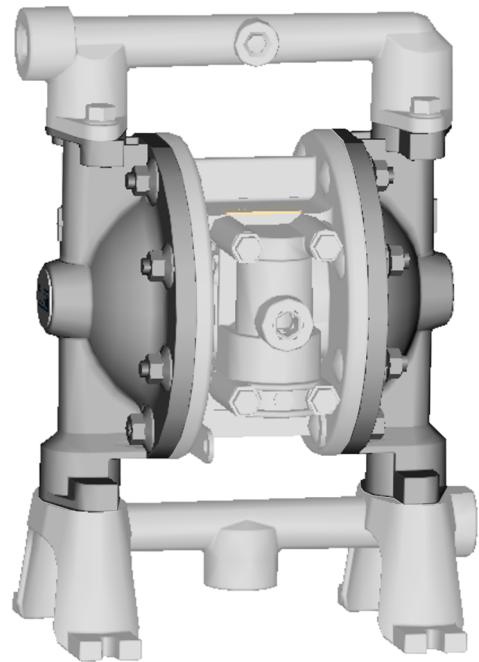

Fig. 8: Material assembly, N24140009

Material assembly

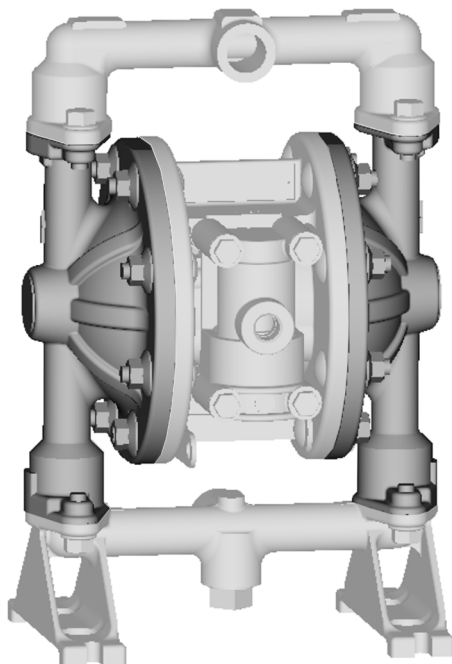

Fig. 7: Material assembly, N24140007

Inlet and outlet manifold

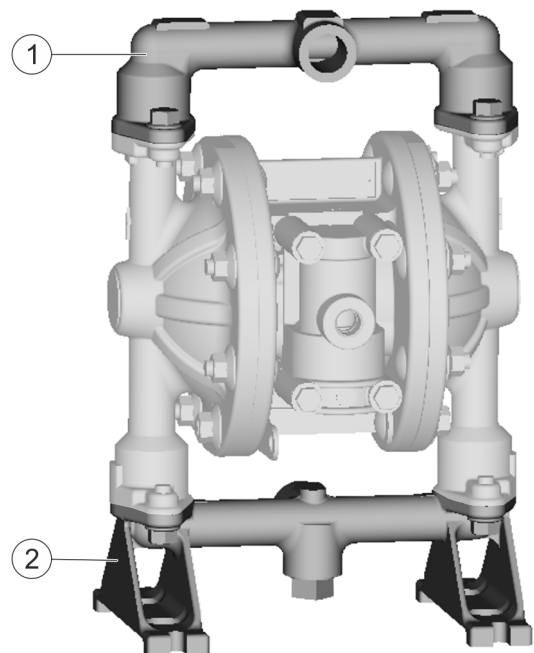

Fig. 9: Inlet and outlet manifold, N24140007

- 1 Outlet manifold for material supply on pressure side
- 2 Inlet manifold for material supply on suction side

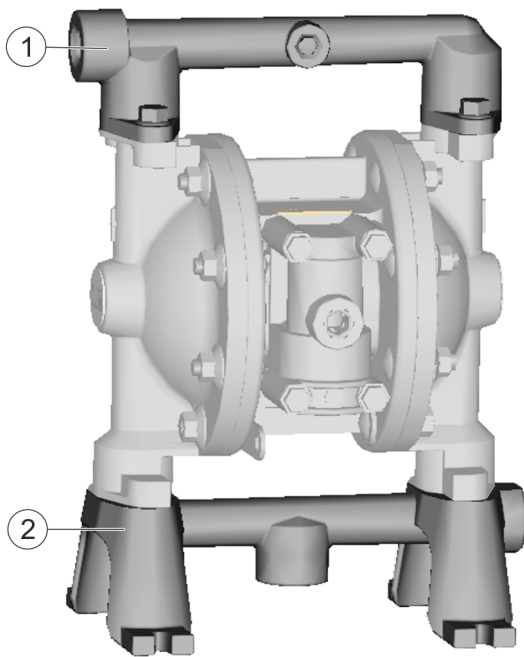

Fig. 10: Inlet and outlet manifold, N24140009

- 1 Outlet manifold for material supply on pressure side
- 2 Inlet manifold for material supply on suction side

3.2 Operation

The pump has an air-driven dual diaphragm that sends a differential pressure to the air chambers. In this way the material chambers can be suctioned up and emptied alternately. Ball valves prevent a return flow of the medium.

The pump starts as soon as compressed air is supplied. The pumping process adjusts to the respective demand. This builds up pressure and keeps it steady. The flow is stopped when the maximum tube pressure is reached. After this, the pumping process is restarted as necessary.

4 Transport, scope of supply and storage

4.1 Transport

! NOTICE!

Incorrect Transport

Improper transportation of die Pumpe may cause the agitator die Pumpeto fall and suffer damage.

- Protect Pumpe from moisture.
- Protect Pumpe from vibrations.
- Use transport locks (e. g. against slipping).

Permissible ambient temperature during the transportation for a few hours:
-40°C to 60°C

4.2 Unpacking

DANGER!

Electrostatically charged plastic films and foils in potentially explosive areas

The foil can charge electrostatically at the time of unpacking. Electrostatic discharge can cause sparks that in explosive atmosphere can cause a fire or an explosion. Serious injury and death could be the consequence.

- Unpack product outside Ex zones.

1. Check the pump packaging for damage. If there is any damage, notify the customer service immediately ↘ “Hotline and Contact”.
2. Remove packing film.
3. Dispose of the packaging professionally.
4. Check pump for damage.
5. Transport pump to the assembly location without packaging film.

4.3 Scope of delivery

The scope of supply only includes the pump.

Personnel:

- » Mechanic

Protective equipment:

- » Protective gloves
- » Protective workwear
- » Anti-Static Safety Boots

1. Check the pump for integrity on receiving it.
2. Report defects immediately ↪ “Hotline and Contact”.

4.4 Storage

Ambient Conditions

! NOTICE!

Damage from improper storage

High load stresses on the packaging can damage the product.

- Do not stack the packaging.

Observe the following environmental conditions for the storage of the pump:

- » Temperature: 10-40°C
- » Humidity: 35 % – 90 %
- » Protection from direct sunlight
- » Protection from cold
- » Protection from vibration
- » Protection from dust and dirt
- » Do not store outdoors.
- » Store in a dry and dust-free place.
- » Do not expose to aggressive media.

Storage of Replacement Parts

The same storage provision as for the pump apply to the replacement parts.

5 Assembly

5.1 Requirements for the Installation point.

Protect pump from vibration damage:

- » Erect mounting feet for the pump on horizontal ground.

5.2 Assembly

i If air containing a lubricant is present in the equipment, the air must be compatible with O-rings and seals in the compressed air part of the pump .

↪ 12.5 “Compressed air quality”

Personnel:

- » Mechanic

Protective equipment:

- » Protective gloves
- » Anti-Static Safety Boots

! NOTICE!

Material damage due to improper assembly

Installing the pump in an incorrect installation position will damage the pump.

- Store the pump in an upright position only.

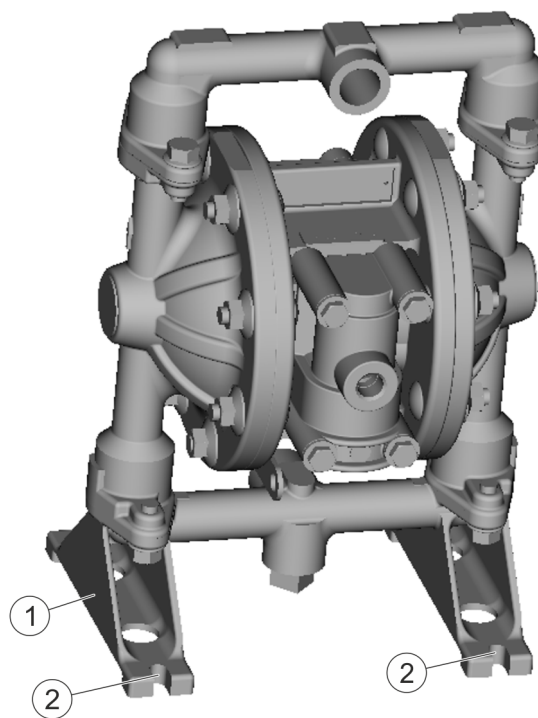

Fig. 11: Assemble the pump, N24140007

Mount the pump on the mounting feet (1) using 4 screws. The recesses (2) for the screws are on the front and back of the pump.

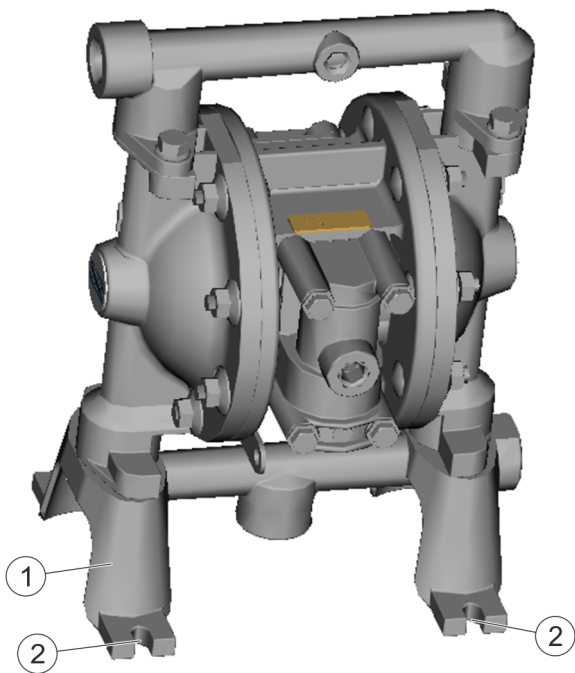

Fig. 12: Assemble the pump, N24140009

Recesses (2) for the screws are on the front and back of the pump.

1. Lightly fix the pump on the mounting feet (1) using 4 screws and grommets ↪ 13.3 “Accessories”.
2. Connect compressed air lines and material line to the pump.
3. Tighten screws carefully.
 - ⇒ After installation, components must not be subject to mechanical stress.

5.3 Assembling ground conductor

EX WARNING!

Sparks due to electrostatic discharge

If die Pumpe is not grounded, there can be an electrostatic charge on the die Pumpe. Electrostatic discharge can cause sparks that in explosive atmosphere can cause a fire or an explosion. Serious injury and death could be the consequence.

- Ground Pumpe as specified.
- Before carrying out any work, make sure that there is no explosive atmosphere.

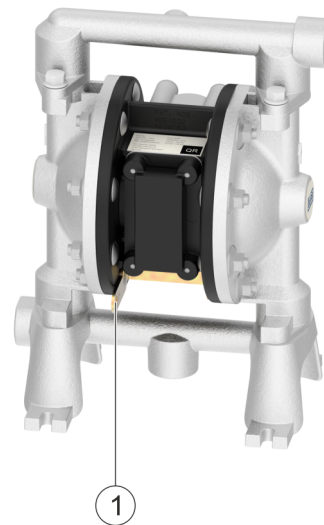

Fig. 13: Connecting Ground

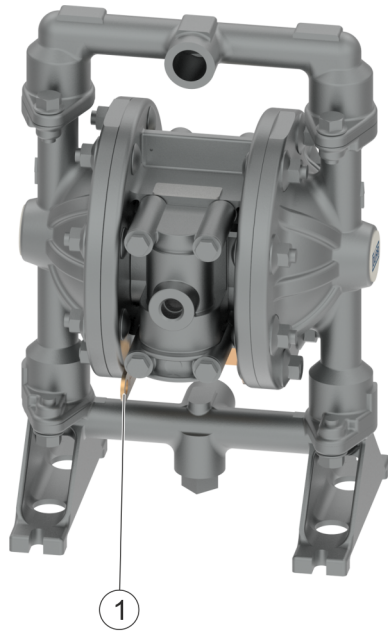

Fig. 14: Connecting Ground

Personnel:

- » Electrician
- » + additional qualification explosion protection

Protective equipment:

- » Protective workwear
- » Protective gloves
- » Anti-Static Safety Boots

1. Assemble ground conductor on the ground connection (1).
2. Measure grounding resistance.

5.4 Connecting
Connecting material supply

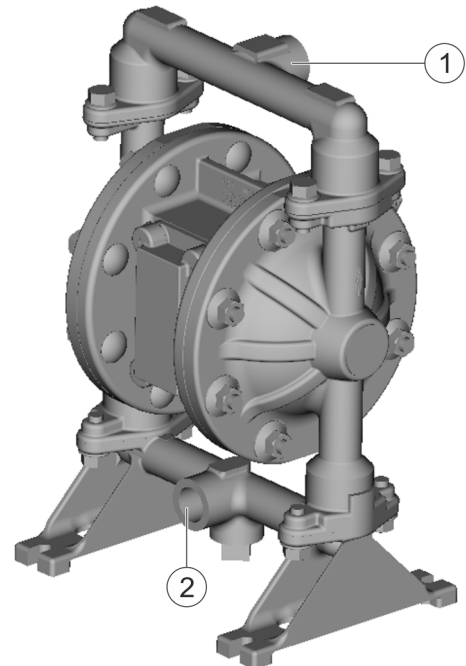

Fig. 15: Material supply connection, N24140007

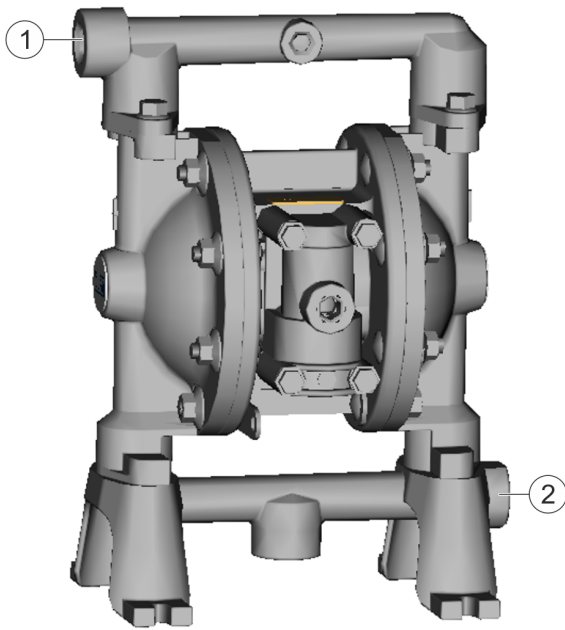

Fig. 16: Material supply connection, N24140009

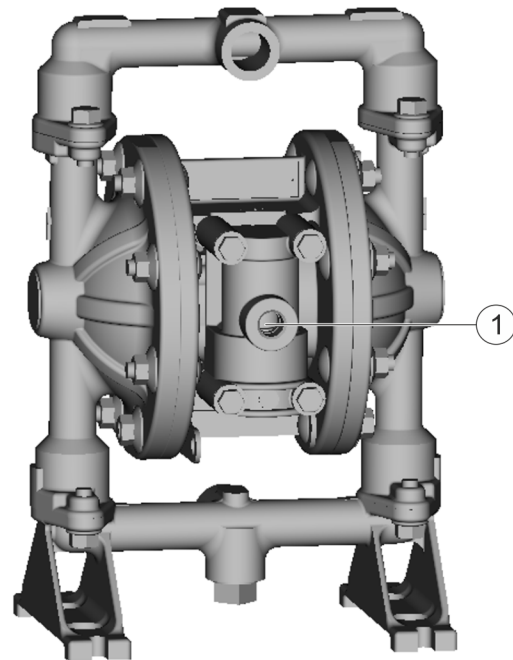

Fig. 17: Compressed air connection, N24140007

Personnel:

- » Mechanic

Protective equipment:

- » Eye protection
- » Protective gloves
- » Anti-Static Safety Boots

1. Connect the pressure side material supply system (1).
2. Connect the suction side material supply system (2).

Connect compressed air supply

⚠ WARNING!

Excessive control air pressure

Excessive control air pressure can damage the pump. Serious injuries and death can be the consequence.

- Do not exceed the control air pressure
 - ↳ 12.4 "Operating values".

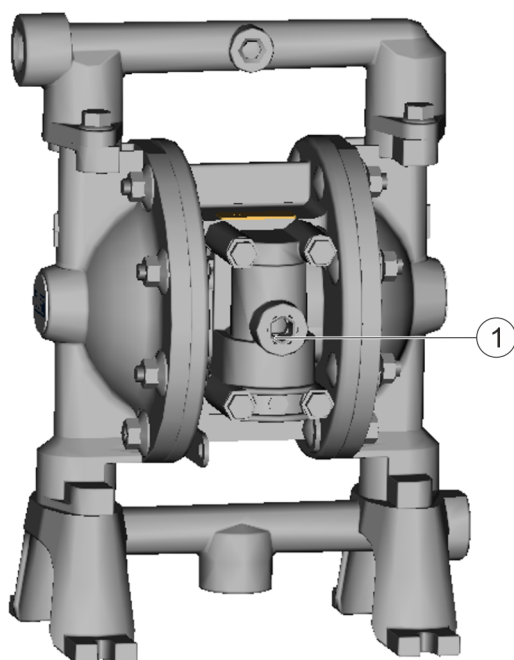

Fig. 18: Compressed air connection, N24140009

Personnel:

- » Mechanic

Protective equipment:

- » Eye protection
- » Protective gloves
- » Anti-Static Safety Boots

1. Install a filter in the air supply line.
 - ⇒ The filter must filter out particles above 50 µm.
2. Connect compressed air hose to the compressed air connection (1).

6 Commissioning

6.1 Safety recommendations

⚠ WARNING!

Excessive input pressure

Charging the pump with excessive input pressure will damage the pump. Serious injuries and death can be the consequence.

- Charge the pump with low pressure at the time of commissioning.
- Before increasing the pressure, check that hoses and connections are seated tightly.
- Increase pressure gradually, until the maximum input pressure is reached.
- Do not exceed maximum input pressure.
 - ↳ 12.4 “Operating values”.

⚠ EX WARNING!

Sparks due to electrostatic discharge

If die Pumpe is not grounded, there can be an electrostatic charge on the die Pumpe. Electrostatic discharge can cause sparks that in explosive atmosphere can cause a fire or an explosion. Serious injury and death could be the consequence.

- Ground Pumpe as specified.
- Before carrying out any work, make sure that there is no explosive atmosphere.

⚠ WARNING!

Escaping material

Escaping compressed material can cause serious injury.

Before commissioning:

- Check ball valve for functioning.

⚠ WARNING!

Danger from harmful or irritant substances

Serious injuries or death can result if you come into contact with dangerous fluids or steam.

- Pumpe Check regularly for leakage. Observe local regulations and maintenance schedule.
- Ensure that the forced ventilation is operational.
- Follow the safety data sheet.
- Wear specified protective clothing.
- Avoid contact (e.g. with eyes, skin).

WARNING!
Unsuitable tools in explosive areas

Tools that do not have Ex approval can generate sparks and cause a fire or an explosion in Ex zones. It can cause serious injuries or death.

- If possible, carry out cleaning and maintenance work outside the Ex zones.
- For work within the Ex zone, use tools with the corresponding Ex labeling.

6.2 Preparing for commissioning

Personnel:

- » Mechanic

Protective equipment:

- » Protective gloves
- » Anti-Static Safety Boots

Carry out the following checks for the operation:

- » Check grounding connection of the pump.
- » Ambient temperature
- » Relative humidity
- » Compressed air connection is flexible and conductive.
- » Connections of the suction and pressure line are designed to be conductive.
- » The connection of the suction and pressure line must be flexible to equalize vibrations of the pump. Connections must not be made using tubes and must be compatible with the material to be pumped.
- » Connected media lines and connections are sealed.
- » Check all screw connections with a torque wrench.
 - ↳ 12.9 “Tightening torques”

6.3 Setting operating parameters

Personnel:

- » Mechanic

Protective equipment:

- » Protective gloves
- » Anti-Static Safety Boots
- » Input pressures of the media supplied via the tube system are within the required ranges
 - ↳ 12.4 “Operating values”.

7 Operation

7.1 Safety recommendations

WARNING!
Hot surfaces

In operation, the surfaces of the product can heat intensely. Contact can cause burn injuries.

- Wear protective hand gloves.

WARNING!
Danger from noise

Disconnecting pressurized pneumatic lines creates loud noises. This might damage the hearing. Before carrying out any work:

- Depressurize pneumatic lines. Secure against reconnection.
- Wear ear protection.

WARNING!
Danger of explosion due to sources of ignition in an explosive atmosphere.

Sparks, open flames and hot surfaces can cause explosions in explosive atmospheres. Serious injury and death could be the consequence.

- Do not use any sources of ignition and no open light in the work area.
- Ensure that the forced ventilation is operational.
- Do not smoke.
- Ground Pumpe.
- Wear suitable protective equipment.

WARNING!
Danger of fire and explosion

Flammable coating materials and their detergents and cleaning agents can cause a fire or an explosion.

- Ensure that the flashpoint of the fluid is at least 15 K above the ambient temperature.
- Note explosion group of the fluid.
- Follow the safety data sheet.
- Ensure that forced ventilation and fire protection equipment are in operation.
- Do not use sources of ignition and open light.
- Do not smoke.
- Check grounding.

**WARNING!****Risk of injury due to escaping material and compressed air**

Escaping compressed material can cause serious injury.

Before carrying out any work:

- Disconnect the system, in which die Pumpe is installed, from compressed air and material supply.
- Secure the system against being switched on again.
- Depressurize the lines.

7.2 General notes

Personnel:

- » Mechanic

Protective equipment:

- » Protective gloves
- » Anti-Static Safety Boots
- » Check state of the pump.
- » If pump temperature and vibrations are too high:
 - » Switch off pump.
 - » Service and repair pump ↪ 10 “Faults”.
- » Clean the pump surface to prevent dust deposition ↪ 8.2 “Cleaning”.

Other checks ↪ 6.3 “Setting operating parameters”.

7.3 Starting Operations

Personnel:

- » Mechanic

Protective equipment:

- » Protective gloves

1. Turn pressure regulator control knob until pump motor starts.
2. Leave pump running slowly until material is sucked in and air is expelled from hose and outlet valve.
3. Close the outlet valve.
4. Stop the pump by putting on maximum load.
5. Check connections for leaks.
6. Adjust pressure regulator as required to achieve desired operating pressure and flow rate.

7.4 Rinsing

7.4.1 Safety recommendations

**NOTICE!****Material damage due to unsuitable rinsing agent**

If the rinsing agent reacts chemically with the components or the material, components get damaged.

- Use only the rinsing agents that are compatible with the components and the material.
- Refer to safety data sheet of material manufacturer.

7.4.2 Flush the pump.

Personnel:

- » Mechanic
- » + additional qualification explosion protection

Protective equipment:

- » Eye protection
- » Protective gloves
- » Protective workwear
- » Respirator mask
- » Use ear protection
- » Anti-Static Safety Boots

Complete the following steps if the pump is not in operation for a longish period:

- » Purge pump with a suitable detergent ↪ 12.7 “Operating and auxiliary materials”.
- » Disconnect compressed air supply to pump.

8 Cleaning

8.1 Safety recommendations

WARNING!

Danger of fire and explosion

Flammable coating materials and their detergents and cleaning agents can cause a fire or an explosion.

- Ensure that the flashpoint of the fluid is at least 15K above the ambient temperature.
- Only electrically conductive containers may be used for the cleaning fluid. Containers must be grounded.
- Note explosion group of the fluid.
- Follow the safety data sheet.
- Ensure that forced ventilation and fire protection equipment are in operation.
- Do not use sources of ignition and open light.
- Do not smoke.
- Ground Pumpe.

WARNING!

Danger of fire and explosion

Sources of ignition in explosive atmosphere can cause a fire or an explosion. Serious injuries and death can be the consequence.

- Before carrying out any cleaning and maintenance work, ensure there is no explosive atmosphere.

WARNING!

Danger from harmful or irritant substances

Serious injuries or death can result if you come into contact with dangerous fluids or steam.

- Pumpe Check regularly for leakage. Observe local regulations and maintenance schedule.
- Ensure that the forced ventilation is operational.
- Follow the safety data sheet.
- Wear specified protective clothing.
- Avoid contact (e.g. with eyes, skin).

NOTICE!

Unsuitable cleaning agents

Unsuitable detergents can cause material damage.

- Only use cleaning agents approved by the material manufacturer.
- Follow safety data sheets.

NOTICE!

Unsuitable Cleaning Tools

Unsuitable cleaning tools can cause damage.

- Only use cloths, soft brushes and paint-brushes.
- Do not use abrasive cleaning tools.
- Do not use compressed air for cleaning.
- Do not use any thinner spray guns.
- Do not use high pressure for cleaning agents.

8.2 Cleaning

Personnel:

- » Cleaning staff

Protective equipment:

- » Eye protection
- » Protective gloves
- » Protective workwear
- » Respirator mask

1. Purge the pump ↪ 7.4 “Rinsing”.
2. Clean pump carefully ↪ 12.7 “Operating and auxiliary materials”.

9 Maintenance

9.1 Safety recommendations

WARNING!

Danger of fire and explosion

Sources of ignition in explosive atmosphere can cause a fire or an explosion. Serious injuries and death can be the consequence.

- Before carrying out any cleaning and maintenance work, ensure there is no explosive atmosphere.

EX WARNING!

Unsuitable replacement parts in explosive areas

Replacement parts not compliant with the specifications of the ATEX guidelines can cause explosions in an explosive atmosphere. Serious injury and death could be the consequence.

- Use exclusively original replacement parts.

! WARNING!

Danger from poisonous aerosols

When the diaphragm is defective, a mixture of paint, solvent and air is leaking from the muffler.

- Wear respiratory protection when working on the diaphragm.
- Carry out larger work on the pump at a suitable work station in the workshop.

! WARNING!

Risk of injury due to escaping material and compressed air

Escaping compressed material can cause serious injury.

Before carrying out any work:

- Disconnect the system, in which die Pumpe is installed, from compressed air and material supply.
- Secure the system against being switched on again.
- Depressurize the lines.

9.2 Maintenance schedule

The maintenance intervals given below are based on experiential values. Adjust maintenance intervals.



If a maintenance assistant is used in the system visualizer, the maintenance intervals of the maintenance assistant are valid.

Interval	Maintenance work
Daily	Check cleanliness.
	Check tightness.
	» ↪ 9.3.3 “Dismantle material assembly.”
	» ↪ 9.3.4 “Dismantle pneumatic assembly”
	Check connections on all hoses and lines.
Weekly	Check noise generation.
	Check for steady delivery pressure.

9.3 Dismantle and assemble

9.3.1 General notes

! NOTICE!

Danger of leakages

Used or incorrectly installed seals can lead to leakage at the valve.

- Use only new seals.
- Do not twist seals when inserting them.

! NOTICE!

Installation of used wear parts

Used wear parts can no longer withstand the loads during operation. Installing used wear parts can cause irreparable damage to the product.

- Assemble only new parts.

9.3.2 Dismantle inlet and outlet manifold

Removing the outlet manifold

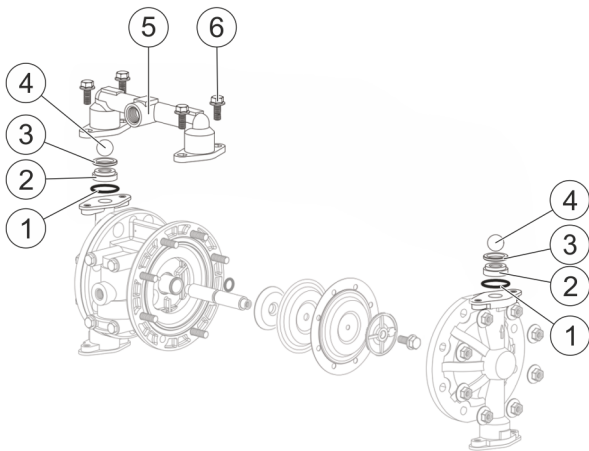

Fig. 19: Central body with outlet manifold

Personnel:

- » Mechanic

Protective equipment:

- » Eye protection
- » Protective gloves
- » Anti-Static Safety Boots

Requirements:

- » Pump is properly disassembled. ↪ 11.1 “Disassembly”

1. Remove 4 nuts (6) on outlet manifold (5).
2. Remove outlet manifold (5) from central body.
3. Remove 2 balls (4), and 2 washers (3).
4. Remove 2 ball seats (2) and 2 O-rings (1).

Installing the inlet manifold

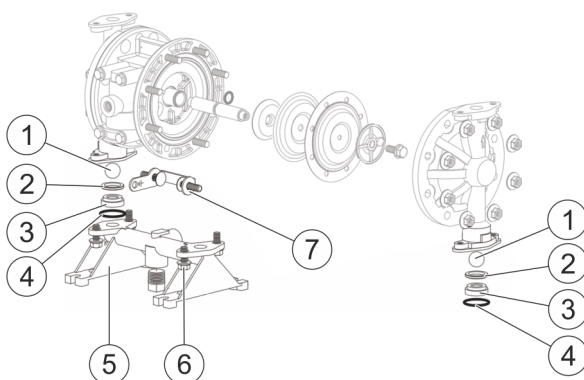

Fig. 20: Central body with inlet manifold

Personnel:

- » Mechanic

Protective equipment:

- » Eye protection
- » Protective gloves
- » Anti-Static Safety Boots

Requirements:

- » Pump is properly disassembled. ↪ 11.1 “Disassembly”

1. Remove 4 screws (6) from outlet manifold (5).
2. Remove outlet manifold (5).
3. Remove 2 balls (1), and 2 washers (2).
4. Remove 2 ball seats (3) and 2 O-rings (4).
5. Remove 2 screws. Remove ground strap (7).

9.3.3 Dismantle material assembly.

Remove material cover and membrane.

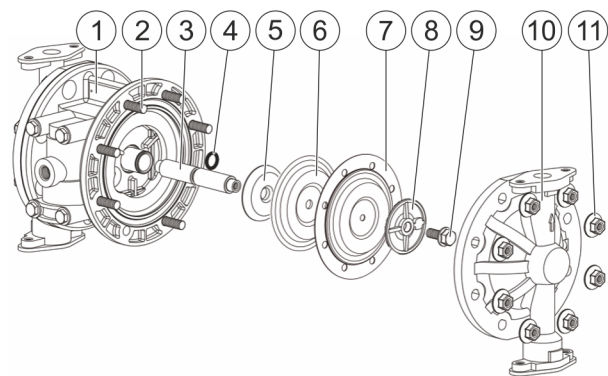

Fig. 21: Material cover and membrane

Personnel:

- » Mechanic

Protective equipment:

- » Eye protection
- » Protective gloves
- » Anti-Static Safety Boots

Requirements:

- » Inlet and outlet manifold are dismantled.

1. Remove 8 nuts (11) and 8 screws (2).
2. Remove material cover (10) from central body (1).
3. Remove diaphragm screw (9) and washers (8).

4. Remove membrane (7) (PTFE models only).
5. Remove membrane (6).
6. Remove washer (5).

Do not damage the surface of the diaphragm rod.

7. Remove membrane rod (3) and O-ring (4) from central body (1).
8. Repeat all steps for the removal of the material cover and membrane on the left side.

9.3.4 Dismantle pneumatic assembly

Dismantling the main valve

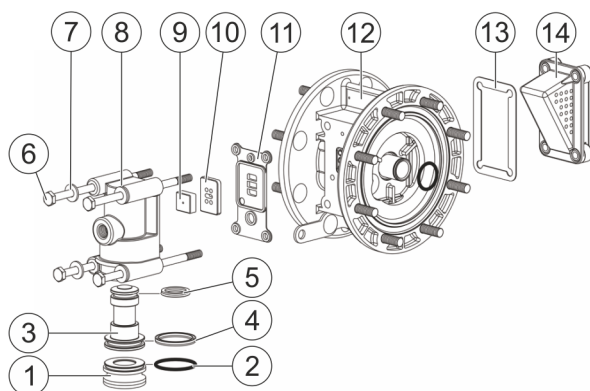

Fig. 22: Main valve with central body

Personnel:

- » Mechanic

Protective equipment:

- » Eye protection
- » Protective gloves
- » Anti-Static Safety Boots

Requirements:

- » Material assembly is dismantled.
1. Remove outlet cover (14) and sealing (13) from the central body (12).
 2. Remove 4 screws (6), 4 washers (7) and sealing (11) from the valve head assembly (8).
 3. Remove valve head assembly (8) from central body (12).
 4. Remove valve disc (10) and valve core (9).

5. Remove piston (1) and control piston (3).
6. Remove O-ring (2) and U-caps (4, 5).

Dismantle control valve

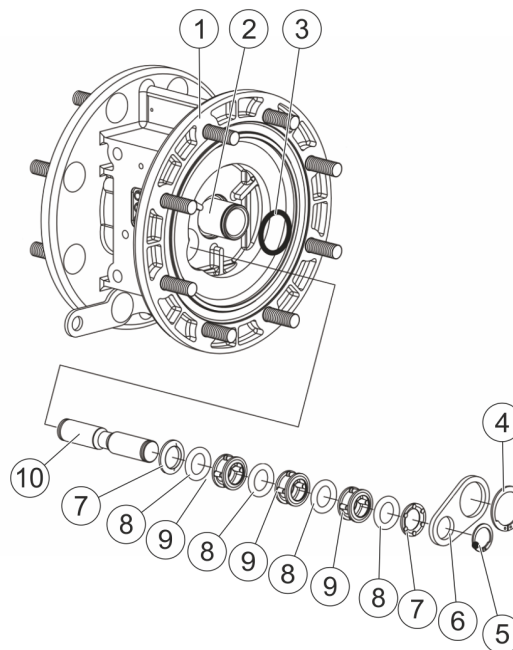

Fig. 23: Control valve with central body

Personnel:

- » Mechanic

Protective equipment:

- » Eye protection
- » Protective gloves
- » Anti-Static Safety Boots

Requirements:

- » Material assembly is dismantled.
1. Remove circlips (4, 5).
 2. Remove disc (6).
 3. Remove tube (2) and O-ring (3) from central body (1).
 4. Remove piston (10), 2 washers (7), 4 O-rings (8) and 3 spacers (9) from the central body (1).

9.3.5 Assemble pneumatic assembly.

Assemble the control valve

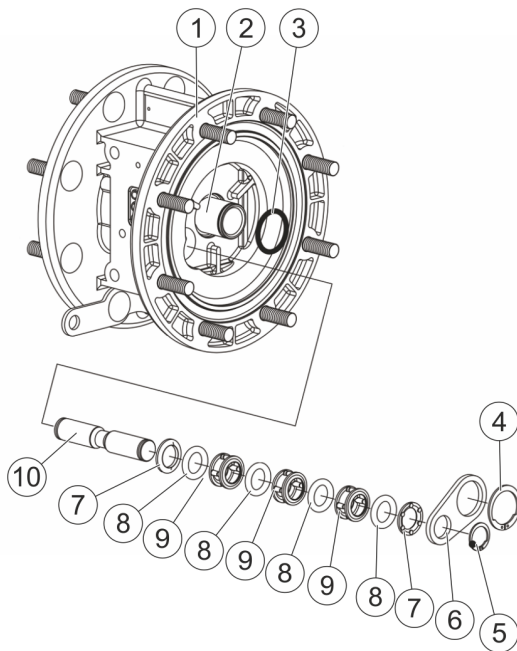

Fig. 24: Control valve with central body

Personnel:

- » Mechanic

Protective equipment:

- » Eye protection
- » Protective gloves
- » Anti-Static Safety Boots

Requirements:

- » Clean work area
 - » Components are cleaned.
 - ↳ 12.7 "Operating and auxiliary materials"
 - » Replace damaged components.
 - ↳ 13.1 "Replacement parts"
 - » Use suitable lubricant.
 - ↳ 12.7 "Operating and auxiliary materials"
1. Lubricate O-rings.
 2. Insert tube (2) and O-ring (3) into central body (1).
 3. Insert piston (10), 2 washers (7), 4 O-rings (8) and 3 spacers (9) into central body (1).
 4. Insert disc (6).
 5. Insert circlips (4, 5).

Assemble main valve

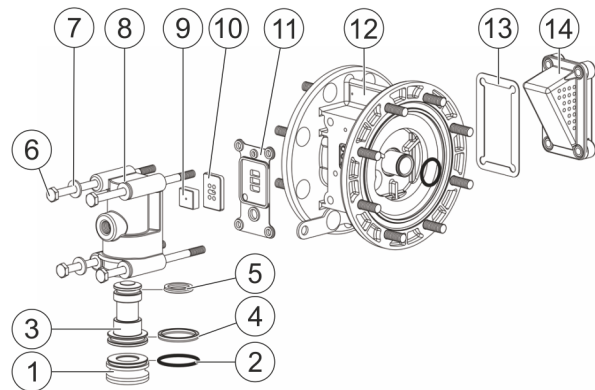

Fig. 25: Main valve with central body

Personnel:

- » Mechanic

Protective equipment:

- » Eye protection
- » Protective gloves
- » Anti-Static Safety Boots

Requirements:

- » Clean work area
- » Components are cleaned.
 - ↳ 12.7 "Operating and auxiliary materials"
- » Replace damaged components.
 - ↳ 13.1 "Replacement parts"
- » Use suitable lubricant.
 - ↳ 12.7 "Operating and auxiliary materials"

1. Lubricate O-rings and U-caps.

Lips of U-caps (4, 5) must oppose each other.

2. Insert piston (1), O-ring (4), control piston (3) and U-cap (5) into valve head assembly (8).
3. Insert sealing (13) and outlet cover (14) into central body (12).
4. Insert valve core (11), valve disc (10) and sealing (11) into valve head assembly (8).
5. Insert main valve into central body (12).
6. Thread-in 4 washers (7) and 4 screws (6) into main valve. Tighten using 1.7 - 2.3 Nm.

9.3.6 Assemble material assembly.

Assemble material cover and membrane.

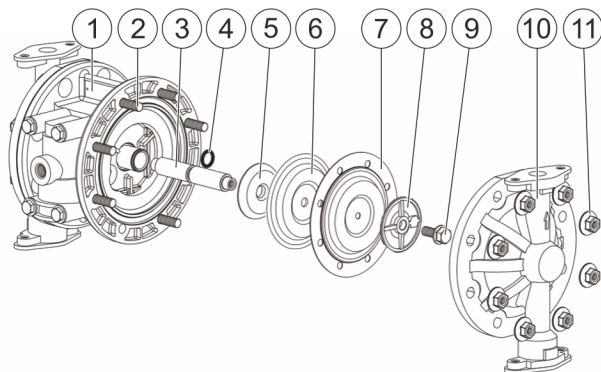

Fig. 26: Material cover and membrane

Personnel:

- » Mechanic

Protective equipment:

- » Eye protection
- » Protective gloves
- » Anti-Static Safety Boots

Requirements:

- » Clean work area
- » Components are cleaned.
 - ↳ 12.7 "Operating and auxiliary materials"
- » Replace damaged components.
 - ↳ 13.1 "Replacement parts"
- » Use suitable lubricant.
 - ↳ 12.7 "Operating and auxiliary materials"

1. Lubricate membrane rod (3) and O-ring (4).
2. Insert O-ring (4) into membrane rod (3).

Do not damage the surface of the diaphragm rod.

3. Insert membrane rod (3) into central body (1).
4. Insert washer (5).
5. Insert diaphragm (6).
6. Insert membrane (7) (PTFE models only).
7. Insert washer (8).
8. Insert diaphragm screw (9). Tighten using 10.7 - 11.9 Nm.
9. Insert material cover (10).

10. Thread-in 8 screws (2) and 8 nuts (11) into material cover (10). Tighten crosswise using 5.6 - 6.8 Nm.

11. Repeat all steps for the installation of the material cover and membrane on the left side.

9.3.7 Assemble inlet and outlet manifolds.

Assemble the inlet manifold

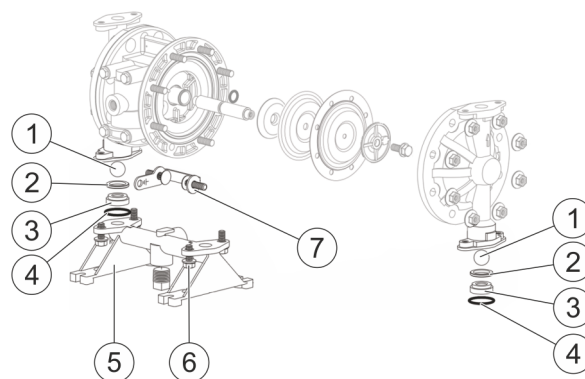

Fig. 27: Central body with inlet manifold

Personnel:

- » Mechanic

Protective equipment:

- » Eye protection
- » Protective gloves
- » Anti-Static Safety Boots

Requirements:

- » Clean work area
- » Components are cleaned.
 - ↳ 12.7 "Operating and auxiliary materials"
- » Replace damaged components.
 - ↳ 13.1 "Replacement parts"
- » Use suitable lubricant.
 - ↳ 12.7 "Operating and auxiliary materials"

1. Lubricate O-rings.
2. Insert 2 O-rings (4), 2 ball seats (3) into inlet manifold (5).
3. Insert 2 washers (2), and 2 balls (1).
4. Install inlet manifold (5) on central body.
5. Thread-in 4 screws (6). Tighten using 5.6 - 6.8 Nm.
6. Mount grounding strap (7) on central body using 2 screws.

Assemble the outlet manifold

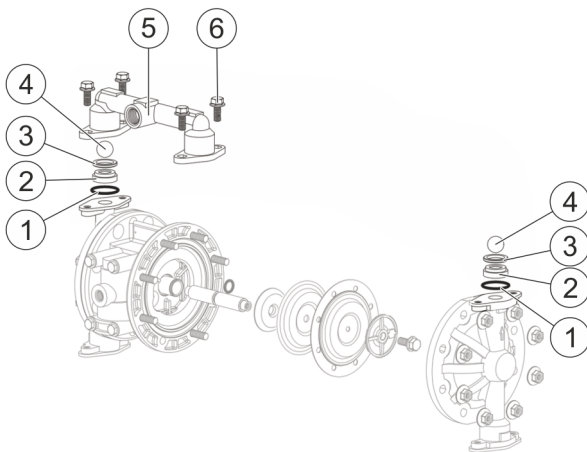

Fig. 28: Central body with outlet manifold

Personnel:

- » Mechanic

Protective equipment:

- » Eye protection

- » Protective gloves
- » Anti-Static Safety Boots

Requirements:

- » Clean work area
- » Components are cleaned.
 - ↳ 12.7 "Operating and auxiliary materials"
- » Replace damaged components.
 - ↳ 13.1 "Replacement parts"
- » Use suitable lubricant.
 - ↳ 12.7 "Operating and auxiliary materials"

1. Lubricate O-rings.
2. Insert 2 O-rings (1) and 2 ball seats (2) into the central body.
3. Insert 2 washers (3), and 2 balls (4).
4. Install inlet manifold (5) on central body.
5. Thread-in 4 screws (6). Tighten using 5.6 - 6.8 Nm.

10 Faults

10.1 Defects table

Fault description	Cause	Remedy
Pump not working despite compressed air supply.	Blocked muffler.	Clean and check; replace if required. » ↪ 12.7 “Operating and auxiliary materials” » ↪ 9.3.4 “Dismantle pneumatic assembly”
	Main valve blocked or soiled.	Clean and check; replace if required. » ↪ 12.7 “Operating and auxiliary materials” » ↪ 9.3.4 “Dismantle pneumatic assembly”
	Pressure line closed.	Open shut-off valve.
	Counter pressure too high	Check line and material.
	Ball stuck to ball seat.	Check pump before standstill.
	Air motor sealing rings swollen.	Replace sealing rings Check ambient temperature
	Assembly position of the pump wrong	Install the pump in an upright position. » ↪ 5.2 “Assembly”
Pump blows air out of muffler.	Main valve seals worn out	Replace. » ↪ 9.3.4 “Dismantle pneumatic assembly”
	Changeover valve seals worn out.	Replace. » ↪ 9.3.4 “Dismantle pneumatic assembly”
	D-valve and ceramic plate worn out.	Replace. » ↪ 9.3.4 “Dismantle pneumatic assembly”
	Changeover valve worn out.	Replace. » ↪ 9.3.4 “Dismantle pneumatic assembly”
No displacement volume	Pump sucks air.	Seal suction line.
	Suction valve closed.	Open suction valve.
	Volume flow rate exceeded,	Check suction capacity. » ↪ 12.4 “Operating values”
	Ball and ball seat on suction side worn out.	Replace. » ↪ 9.3.2 “Dismantle inlet and outlet manifold”
	Foreign body between ball and ball seat	Cleaning » ↪ 12.7 “Operating and auxiliary materials”
Low displacement volume	Blocked muffler.	Clean and check; replace if required.

Fault description	Cause	Remedy
		<ul style="list-style-type: none"> » ↪ 12.7 “Operating and auxiliary materials” » ↪ 9.3.4 “Dismantle pneumatic assembly”
	Air inlet blocked.	Clean and check; replace if required. <ul style="list-style-type: none"> » ↪ 12.7 “Operating and auxiliary materials” » ↪ 9.3.4 “Dismantle pneumatic assembly”
	Air line too small	Replace line.
	Air flow too low	Increase air flow.
	Pipe blocked.	Cleaning <ul style="list-style-type: none"> » ↪ 12.7 “Operating and auxiliary materials”
	Insufficient compressed air supply	Check the feed line.
	Viscosity too high	Use material with lower viscosity.
Pump at standstill after filling lines	Air pressure too low	Increase air pressure. <ul style="list-style-type: none"> » ↪ 12.4 “Operating values”
	Viscosity too high	Increase air pressure. <ul style="list-style-type: none"> » ↪ 12.4 “Operating values”
	Pump head too high	Increase air pressure. <ul style="list-style-type: none"> » ↪ 12.4 “Operating values”
Material leaks from muffler.	Diaphragm torn or damaged.	Replace the diaphragm. <ul style="list-style-type: none"> » ↪ 9.3.3 “Dismantle material assembly.”
	Diaphragm screw loose.	Tighten diaphragm screw.
Air in material	Diaphragm torn or damaged.	Replace the diaphragm. <ul style="list-style-type: none"> » ↪ 9.3.3 “Dismantle material assembly.”
	Diaphragm screw loose.	Tighten diaphragm screw.
	Pump sucks air.	Seal suction line.
Diaphragm leaking	Loose screws	Check torques. <ul style="list-style-type: none"> » ↪ 12.9 “Tightening torques”
	Chemical incompatibility	Replace material.
Manifold leaking	Loose screws	Check torques. <ul style="list-style-type: none"> » ↪ 12.9 “Tightening torques”
	Chemical incompatibility	Replace material.
Insufficient suction head	Ball and ball seat leaking	Replace. <ul style="list-style-type: none"> » ↪ 9.3.2 “Dismantle inlet and outlet manifold”
	Foreign body between ball and ball seat	Cleaning

Fault description	Cause	Remedy
		» ↪ 12.7 “Operating and auxiliary materials”
	Dry pump	Fill pump (use foot valve if required).
	Viscosity too high	Use material with lower viscosity.
	Material density too high	Use material with lower density.
Diaphragm is damaged.	Foreign body in material	Install filter.
	Chemical incompatibility	Replace material.
	Thermal deformation	Replace material.
	-	Replace the diaphragm. » ↪ 9.3.3 “Dismantle material assembly.”
Ball is deformed.	Chemical incompatibility	Replace material.
	Thermal deformation	Replace material.
	-	Replace ball. » ↪ 9.3.2 “Dismantle inlet and outlet manifold”
	Pressure shocks	Use pulsation damper.

11 Disassembly and Disposal

11.1 Disassembly

Turn off compressed air supply

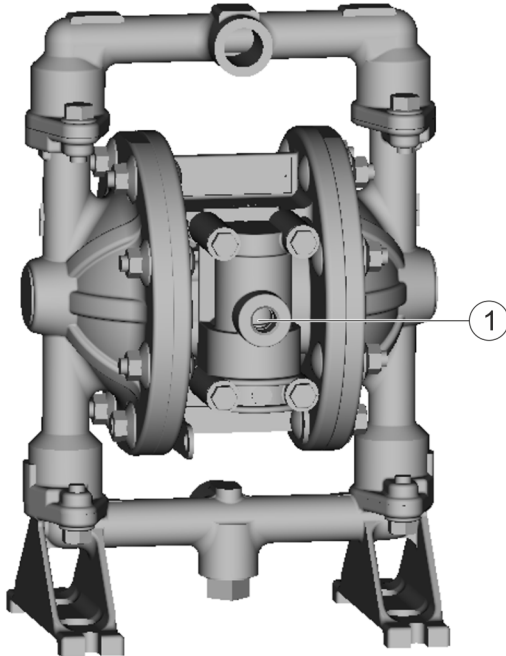

Fig. 29: Compressed air connection, N24140007

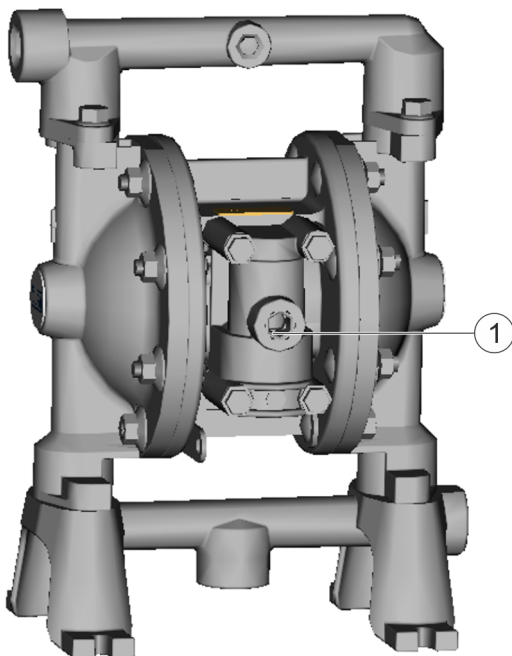

Fig. 30: Compressed air connection, N24140009

Personnel:

- » Mechanic

Protective equipment:

- » Eye protection
- » Protective gloves
- » Anti-Static Safety Boots
- » Protective workwear

1. Disconnect compressed air supply to the pump. Secure against reconnection.
2. Remove compressed air connection (1) from pump.

Switching off material supply

WARNING!

Risk of injury due to escaping material and compressed air

Escaping compressed material can cause serious injury.

Before carrying out any work:

- Disconnect the system, in which die Pumpe is installed, from compressed air and material supply.
- Secure the system against being switched on again.
- Depressurize the lines.

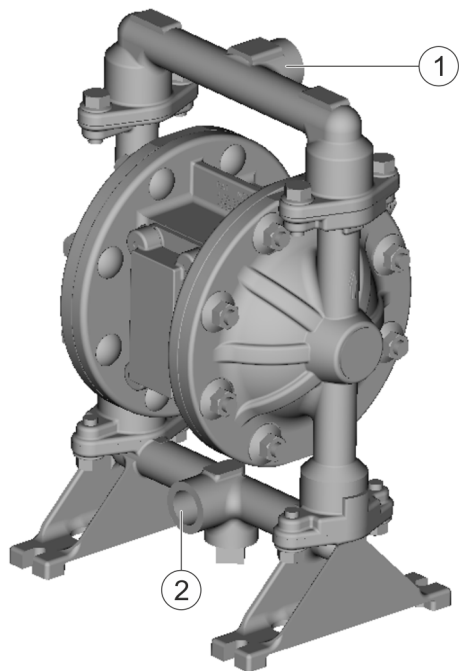

Fig. 31: Material supply connection, N24140007

- 1 Pressure side connection for material supply
- 2 Suction side connection for material supply

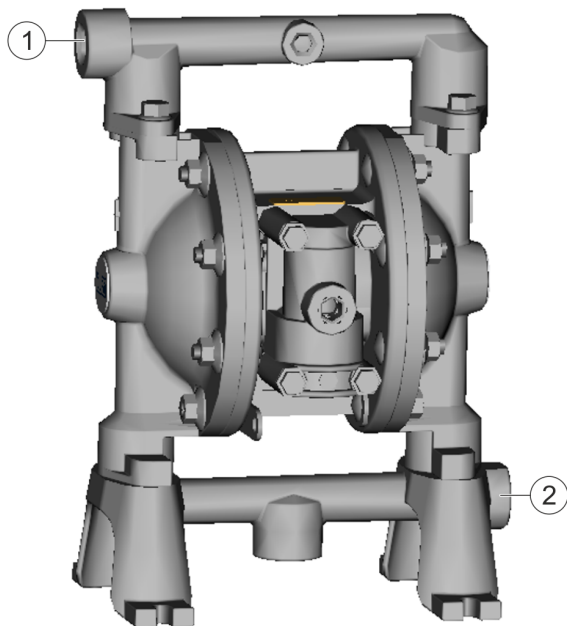

Fig. 32: Material supply connection, N24140009

- 1 Pressure side connection for material supply
- 2 Suction side connection for material supply

Personnel:

- » Mechanic

Protective equipment:

- » Eye protection
- » Protective gloves
- » Anti-Static Safety Boots
- » Protective workwear

1. Relieving Pressure:

- » Switch off suction side material supply. Secure against reconnection.
- » Disconnect material supply system on pressure side. Secure against reconnection.
- » Remove suction side and pressure side connections.

2. Drain material residue from pump into a container.

3. Purge pump with suitable detergent ↗ 12.7 "Operating and auxiliary materials".

Disassemble pump

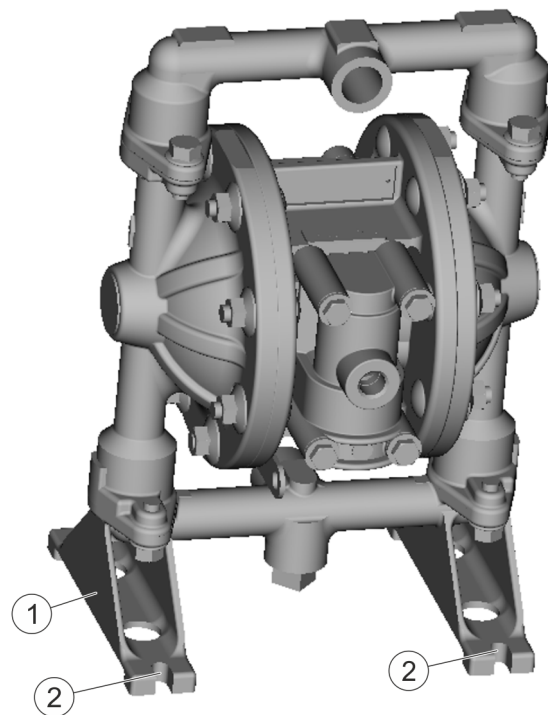

Fig. 33: Disassemble the pump, N24140007

11.2 Disposal

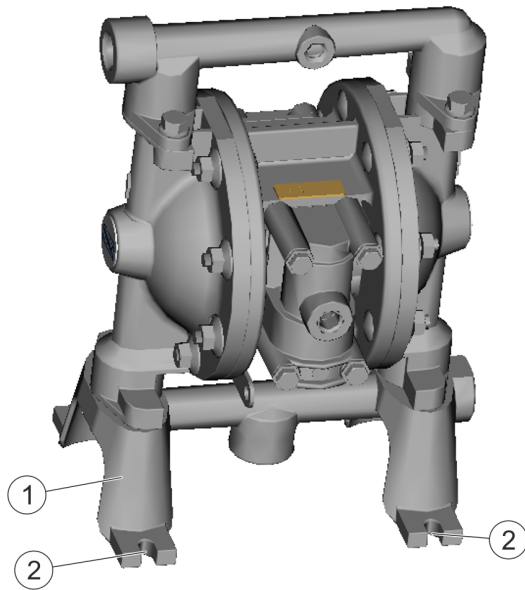

Fig. 34: Disassemble the pump, N24140009

Personnel:

- » Mechanic

Protective equipment:

- » Eye protection
- » Protective gloves
- » Anti-Static Safety Boots
- » Protective workwear

1. Loosen screws in the recesses (2) of the mounting feet (1).
2. Remove pump.

ENVIRONMENT!

Improper waste disposal

Improper waste disposal threatens the environment and prevents re-use and recycling.

- Clean components before their disposal.
- Always dispose of components in accordance with their characteristics.
 - ↳ 12.8 "Materials used"
- Collect leaked out utilities and auxiliaries completely.
- Dispose of work equipment soaked in coating materials or operating substances according to the disposal provisions in force.
- Dispose of utilities and auxiliaries according to the disposal provisions in force.
- In case of doubt, refer to the local disposal authorities.

Requirements:

- » Pump has been cleaned ↳ 8.2 "Cleaning" and purged ↳ 7.4 "Rinsing".
- » Pump has been disassembled ↳ 11.1 "Disassembly".

Personnel:

- » Mechanic
- » + additional qualification explosion protection

Protective equipment:

- » Protective gloves
- » Eye protection
- » Anti-Static Safety Boots

1. Dispose of material residue from pump professionally.
2. Remove the seals. Ensure professional disposal.
3. Dispose of individual parts of the pump professionally.

12 Technical data

12.1 Dimensions and weight

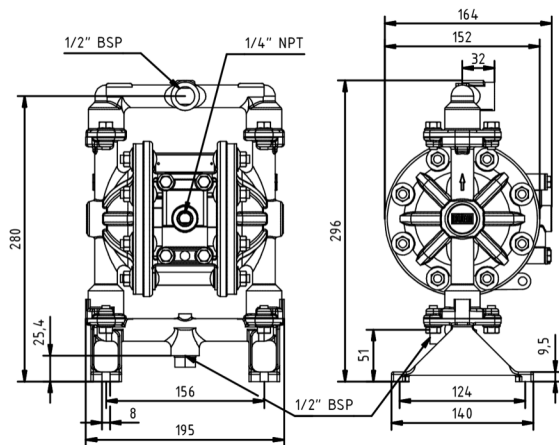

Fig. 35: Dimensions, N24140007

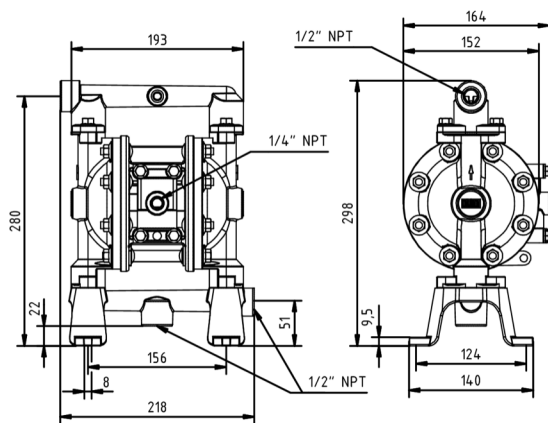

Fig. 36: Dimensions, N24140009

N24140007

Detail	Value
Height	296 mm
Width	195 mm
Depth	164 mm
Particle size max.	2.4 mm
Weight	6.6 kg

N24140009

Detail	Value
Height	298 mm
Width	218 mm

Detail	Value
Depth	164 mm
Particle size max.	2.4 mm
Weight	3.8kg

12.2 Connections

Detail	Value
Compressed air connection	1/4" NPT (IG)
Inlet connection	1/2" BSP (IG)
Outlet connection	1/2" BSP (IG)

12.3 Operating conditions

Detail	Value
Operating temperature, min.	10 °C
Operating temperature, max.	50 °C

12.4 Operating values

Detail	Value
Control air pressure, max.	6.9 bar
Material output pressure, max.	0.7 bar
Material input pressure, max.	16 l/min
Flow rate, max.	0.15 l
Displacement volume per cycle	71.7 dB(A)
Sound pressure level (L _{Aeq})	

12.5 Compressed air quality

- » Purity classes following ISO 8573-1::2010 1:3:1 1:4:1
- » Limitations for purity class 4 (pressure dew point max.):
 - » ≤ -3°C at 7bar absolute
 - » ≤ +1°C at 9bar absolute
 - » ≤ +3°C at 11bar absolute

12.6 Type plate

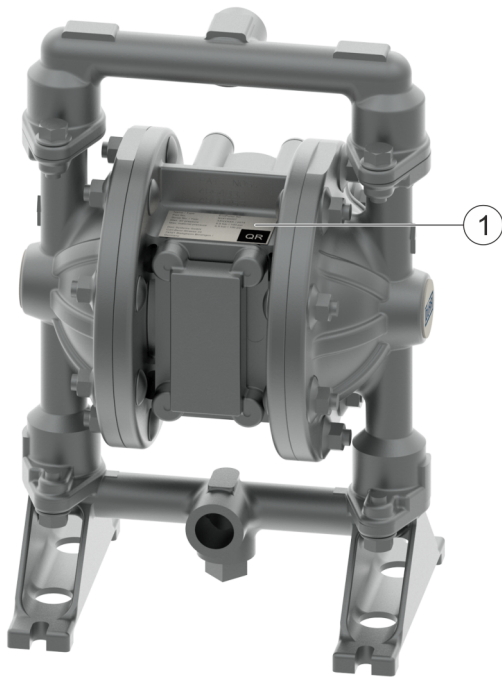

Fig. 37: Position of type plate, N24140007

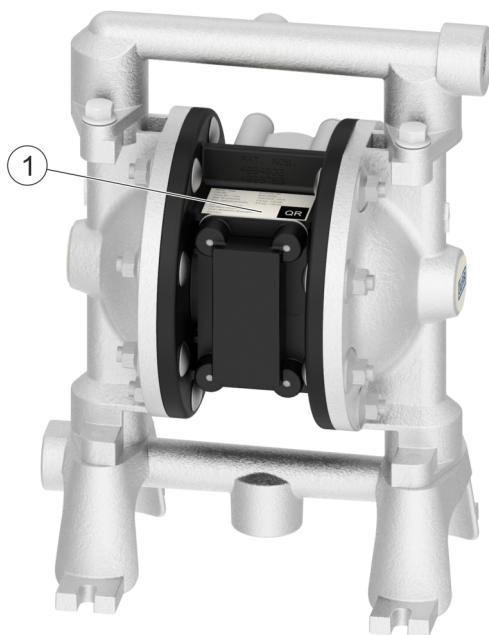

Fig. 38: Position of type plate, N24140009

The type plate (1) shows the following details:

- » Product denomination
- » Material number
- » Year of manufacture
- » Serial number
- » Maximum air pressure
- » Maximum material pressure
- » Manufacturer
- » QR code
- » CE labeling
- » EX labeling

12.7 Operating and auxiliary materials

Material side	Specification
Thread	Loctite® 271
O-rings, U-caps, contact surfaces	Lubricants, free of paint-wetting impairment substances

Compressed air side	Specification
O-rings, U-caps, contact surfaces	Lubricants, free of paint-wetting impairment substances

Cleaning agents

Use only approved cleaning agents that:

- » are suitable for use in explosion hazardous areas.
- » are compatible with the materials used.
 - ↳ 12.8 “Materials used”

Material	Auxiliary material
Conventional paint	Thinner
Water-based paints	Cleaning agents
Stainless steel / aluminum parts	Thinner

Detergent

Use only approved rinsing agents that:

- » are suitable for use in explosion hazardous areas.
- » are compatible with the pumped material.
- » are compatible with the materials used.
 - ↳ 12.8 “Materials used”

12.8 Materials used

N24140007

Detail	Value
Ball	PTFE
Ball seat	Stainless steel
Parts in contact with material	PTFE, stainless steel

N24140009

Detail	Value
Ball	PTFE
Ball seat	Stainless steel
Parts in contact with material	PTFE, stainless steel, aluminum

12.9 Tightening torques

Material side	Value
Screws/ nuts	5.6 - 6.8 Nm
Diaphragm screw	10.7 - 11.9 Nm

Compressed air side	Value
Screws	1.7 - 2.3 Nm

12.10 Characteristic curve of the outflow rate

The rate refers to water at ambient temperature.

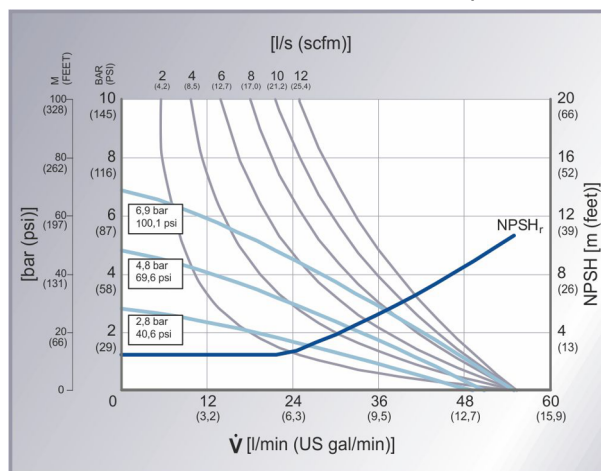

Fig. 39: Flow rate diagram, N24140007

[l/s (scfm)] Air consumption
 [bar (psi)] Pump head
 NPSH [m (feet)] Net positive suction head
 [l/min (US gal/min)] Volume flow

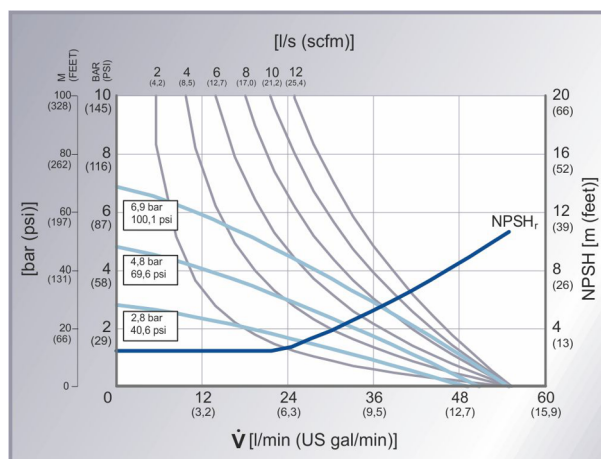

Fig. 40: Outflow rate diagram, N24140009

[l/s (scfm)] Air consumption
 [bar (psi)] Pump head
 NPSH [m (feet)] Net positive suction head
 [l/min (US gal/min)] Volume flow

13 Replacement parts, tools and accessories

13.1 Replacement parts

Position numbers refer to figures in Chapter 9.3 "Dismantle and assemble".

Replacement parts are only available as repair kit.

Replacement parts material assembly

Item	Reference	Denomination	Quantity	Order #
4	Fig. 21	O-ring	1	Included in repair kit N24960007
5		Diaphragm	2	
6		Diaphragm	2	
1	Fig. 19	O-ring	4	
4	Fig. 20			
3	Fig. 19	Ball seat	4	
3	Fig. 20			
1	Fig. 19	Ball	4	
1	Fig. 20			
-	-	Lubricants, free of paint-wet- ting impairment substances	1	

Replacement parts pneumatic assembly

Item	Reference	Denomination	Quantity	Order #
3	Fig. 23	O-ring	2	Included in repair kit N24960008
8		O-ring	4	
5		Circlip	2	
13	Fig. 22	Seal	1	
11		Seal	1	
2		O-ring	1	
4		U-cap	1	
5		U-cap	1	
9		Valve core	1	
10		Valve disc	1	
-	-	Lubricants, free of paint-wet- ting impairment substances	1	

13.2 Tools

There are no special tools available for this product.

13.3 Accessories

There are no accessories available for this product.

13.4 Order



WARNING!

Unsuitable replacement parts in explosive areas

Replacement parts not compliant with the specifications of the ATEX guidelines can cause explosions in an explosive atmosphere. Serious injury and death could be the consequence.

- Use exclusively original replacement parts.



WARNING!

Unsuitable replacement parts

Replacement parts of third-party suppliers may possibly not be able to hold the loads. Serious injury and death could be the consequence.

- Use exclusively original replacement parts.

Ordering replacement parts, tools and accessories as well as information on products that are listed without order number → “Hotline and Contact”.

14 INDEX

A	
Accessories	34
Advanced training	7
Ambient Conditions	11
Assembly	11
Control valve	22
Ground conductor	12
Inlet manifold	23
Main valve	22
Material cover	23
Membrane	23
Outlet manifold	24
B	
Brief description	5
C	
Characteristic curve	
Outflow rate	33
Cleaning	18
Safety notes	18
Commissioning	
Setting operating parameters	16
Compressed air connection	31
Connect	
Compressed air line	13
Material supply	13
Connections	31
Contact	3
D	
Dimensions	
Depth	31
Height	31
Particle size	31
Weight	31
Width	31
Disassembly	
Pump	29
Switching off material supply	28
Turn off compressed air supply	28
Dismantle	
Control valve	21
Inlet manifold	20
Main valve	21
Material cover	20
Membrane	20
Outlet manifold	20
E	
Ex protection	
Ex labeling	6
F	
Faults	25
Function	10
G	
Grounding	12
H	
Hotline	3
I	
Information about the document	3
Installation	
Inlet manifold	8
Material assembly	8
Material supply	8
Outlet manifold	8
Pneumatic assembly	8
M	
Maintenance schedule	19
Material number	3
Materials used	
Ball	33
Ball seat	33
Parts in contact with material	33
N	
Notes	
Representation	5
O	
Operating and auxiliary materials	32
Operating parameters	16
Operating temperature	31
Order	34
Overview	5
P	
Personal protective equipment	7
Product name	3
Protective equipment	7
Electrostatic discharge	7
Purging	17
Q	
Qualification	7
Qualification of the personnel	7
R	
Replacement parts	
Material assembly	33
Pneumatic assembly	33

Representation		Technical Data	
Notes	5	Connections	31
Residual risks	6	Tools	34
Grounding	6	Training	7
S		Transport inspection	11
Safety		Transportation	10
Notes	5	Turn off compressed air supply	28
Residual risks	6	Type plate	32
Safety notes		U	
Maintenance	18	Unpacking	10
Scope of Supply	11	Use	6
Scope of the document	3	W	
Service	3	Wrong use	6
Storage	11		
T			
Technical data			
Compressed air quality	31		

Dürr Systems AG
Application Technology
Carl-Benz-Str. 34
74321 Bietigheim-Bissingen
Germany
www.durr.com
Telefon: +49 (0)7142 78-0
Translation of the original operation manual

Weitergabe und Vervielfältigung dieses Dokuments sowie Verwertung und Mitteilung seines Inhalts sind nicht gestattet, soweit nicht ausdrücklich zugestanden. Zuwiderhandlungen verpflichten zu Schadenersatz. Alle Rechte für den Fall der Patenterteilung oder Gebrauchsmuster-Eintragung vorbehalten.

© Dürr Systems AG 2015

www.durr.com