

LEADING IN
PRODUCTION
EFFICIENCY



EcoFlow LPF P

Low Pressure Regulator Flow

Operation manual

MRE00008EN, V02

N2621...





Information about the document

This document describes the correct handling of the product.

- Read the document prior to every activity.
- Prepare the document for the application.
- Pass on the product only together with the complete documentation.
- Always follow safety instructions, handling instructions and specifications of every kind.
- Illustrations can deviate from the technical construction.

Validity range of the document

This document describes the following products:

N26210002 EcoFlow LPF P 5 8 G3/8" SST	
N26210003 EcoFlow LPF P 15 8 G3/8" SST	
N26210007 EcoFlow LPF P 5 8 G3/8" SST G1/8"	
N26210008 EcoFlow LPF P 15 8 G3/8" SST G1/8"	

Hotline and Contact

If you have queries or would like technical information, please contact your dealer or sales partner.

TABLE OF CONTENTS

1	Product overview	4	8	Maintenance	16
	1.1 Overview.....	4		8.1 Safety recommendations.....	16
	1.2 Short description.....	4		8.2 Maintenance schedule.....	18
2	Safety	4		8.3 Dismantling.....	19
	2.1 Presentation of Notes.....	4		8.4 Assembly.....	20
	2.2 Intended Use.....	5	9	Faults	22
	2.3 Residual risks.....	6		9.1 Defects table.....	22
	2.4 Property damage.....	6	10	Disassembly and Disposal	23
	2.5 Staff qualification.....	6		10.1 Safety recommendations....	23
	2.6 Personal protective equip- ment.....	7		10.2 Disassembly.....	23
				10.3 Disposal	24
3	Transport, scope of supply and storage	8	11	Technical data	25
	3.1 Transport.....	8		11.1 Dimensions and weight.....	25
	3.2 Unpacking.....	8		11.2 Connections.....	25
	3.3 Scope of delivery.....	8		11.3 Operating conditions.....	26
	3.4 Handling of packaging material.....	8		11.4 Emissions.....	26
	3.5 Storage.....	8		11.5 Operating values.....	26
				11.6 Compressed air quality.....	26
4	Assembly	8		11.7 Type plate.....	26
	4.1 Requirements for the Installation point.....	8		11.8 Materials used.....	27
	4.2 Assembly.....	9		11.9 Operating and auxiliary materials.....	27
	4.3 Assemble pressure gage.....	10		11.10 Material specification.....	27
5	Commissioning	11	12	Replacement parts and acces- sories	28
	5.1 Safety Instructions.....	11		12.1 Replacement parts.....	28
	5.2 Commissioning.....	12		12.2 Accessories.....	29
				12.3 Order.....	30
6	Operation	13			
	6.1 Safety recommendations.....	13			
	6.2 Rinsing.....	14			
	6.3 Relieving pressure.....	15			
7	Cleaning	15			
	7.1 Safety recommendations	15			
	7.2 Cleaning.....	16			

1 Product overview

1.1 Overview

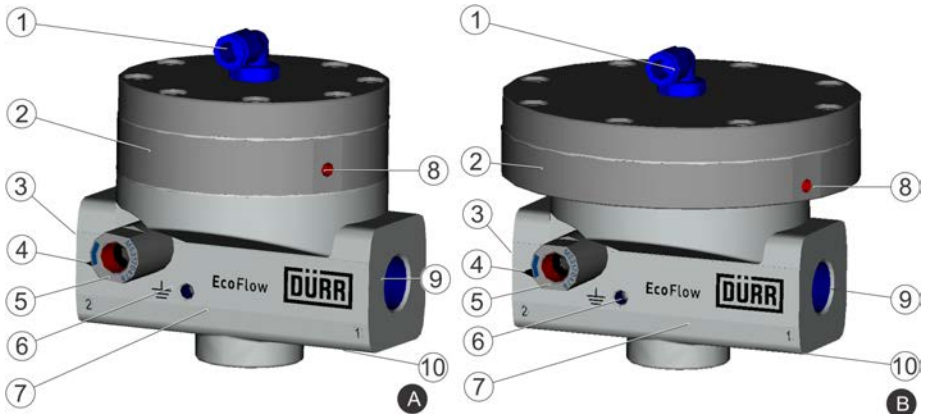

Fig. 1: Product overview, example

- A N26210002 / N26210007
- B N26210003 / N26210008
- 1 Connection for control air
- 2 Spacer ring
- 3 Material outlet
- 4 Display of flow direction

- 5 Pressure gage connection (only N26210007 / N26210008)
- 6 Ground connection
- 7 Regulator housing
- 8 Leakage connection
- 9 Material inlet
- 10 Bore for angle support

1.2 Short description

The low pressure controller (hereafter called "Regulator") reduces the pressure in the supply line of an application system by means of the control air to the required material pressure. It protects the downstream devices from excessive pressure.

2 Safety

2.1 Presentation of Notes

The following notes can appear in this instruction:



DANGER!

High risk situation that can lead to serious injuries or death.



WARNING!

Medium risk situation that can lead to serious injuries or death.



CAUTION!

Low risk situations that can lead to minor injuries.



NOTICE!

Situations that can lead to material damage.



ENVIRONMENT!

Situations that can lead to environmental damage.



Additional information and recommendations.

2.2 Intended Use

Use

The low pressure controller **EcoFlow LPF** serves exclusively for material pressure control in the supply line of the application systems in the designate ATEX area and adhering to the approved technical data ↗ 11 "Technical data".

The low pressure controller is approved for use in explosive areas of Ex zones 1 and 2. The fluids used must conform to the explosion group IIA.



The low pressure controller for fluids does not fall in one of the categories I- IV of the pressure devices guidelines. The low pressure controller is designed and manufactured as specified in article 3 para 3 of 97/23/EC from 2016 onwards in article 4 para 3 of 2014/68/EU.

Misuse

If used improperly, it can cause serious injuries.

Examples of wrong use are:

- Use in explosive areas Ex zone 0
- Use of unapproved materials
- Use without integration into parent process control
- Making conversions or changes on your own

EX labeling

 II 2G Ex h IIA T6 Gb X

- II - Device group II: all areas except mining
- 2G - Device category: 2 (for gaseous atmosphere)
- h - Ignition protection category
- IIA - Explosion group
- T6 - Temperature class
- Gb - Device category and device protection level: Gb (zone 1)
- X - Restriction: The device is configured for operation in an ambient temperature of 15°C to 40°C.

2.3 Residual risks

Explosion

Sparks, open flames and hot surfaces can cause explosions in explosive atmospheres. Serious injury and death could be the consequence.

- Before carrying out any work on the product, ensure a non-explosive atmosphere.
- Do not use sources of ignition and open light.
- Do not smoke.
- Ground the product.
- Wear suitable protective equipment.

Flammable coating materials and their detergents and cleaning agents can cause a fire or an explosion.

- Ensure that the flashpoint of the fluid is at least 15K above the ambient temperature.
- Observe explosion group of the coating materials and their detergents and cleaning agents.
- Follow the safety data sheet.
- Ensure that technical ventilation and fire protection equipment are in operation.
- Do not use sources of ignition and open light.
- Do not smoke.
- Ground the product.
- Wear suitable protective equipment.

Danger due to escaping material

Material escaping under pressure can cause serious injuries.

Before the product:

- Switch off the system.
- Disconnect the system from energy and material supply.
- Depressurize the lines.
- Secure the system against switching on again.

2.4 Property damage

Hardening material

If the material in the product hardens, the product will be damaged or destroyed.

- 1K material: Note curing time ↪ 11.10 “Material specification”
- 2K material: Observe pot time ↪ 11.10 “Material specification”
- Purge product ↪ 6.2 “Rinsing”, e.g. in the case of:
 - Production interruptions
 - Production end

2.5 Staff qualification



WARNING!

Inadequate qualification

Wrong estimation of dangers can cause serious injury or death.

- Only sufficiently qualified persons may execute all work.
- Some work requires additional qualification. Additional qualifications of specialized personnel are marked with a “+”.

This document is intended for qualified personnel in industry and craftsmanship.

Cleaning staff

The cleaning staff receives regular instructions from the operator about the following contents:

- Using the product
- Handling cleaning tools
- Handling cleaning agents
- Technical Measures for occupational safety and health

Electrician

Electricians assemble, install, service and repair electrical systems in a professional manner.

Furthermore, electrical engineers have the following knowledge:

- Guidelines, Standards and Rules of Engineering
- Local conditions
- Electrical Systems and Their Loading Limits
- Technical Measures for occupational safety and health

Mechanic

The mechanic is trained specifically for the field of work in which he works.

Furthermore, he has the following knowledge:

- Guidelines, Standards and Rules of Engineering
- Local conditions
- Technical Measures for occupational safety and health

The mechanic is responsible for the following activities on equipment and components:

- Assembly
- Waiting
- Maintenance
- Disassembly

+ additional qualification explosion protection

In addition to the knowledge of the various specialist fields, the mechanic has knowledge of regulations and safety measures when working in potentially explosive areas.

Dürr Systems offers special product training for ↪ "Hotline and Contact".

2.6 Personal protective equipment

When working in explosive areas, the protective clothing, including gloves, must meet the requirements of DIN EN 1149-5. Footwear must meet the requirements of EN ISO 20344 and EN IEC 61340-4-3. The volume resistivity must not exceed $100\text{M}\Omega$.

Wear the specified personal protective equipment when working. Provide the following personal protective equipment:



Eye protection

Protects eyes from dust, paint drops and particles.



Protective gloves

Protect the hands from:

- mechanical forces
- Thermal forces
- Chemical effects



Protective workwear

Tight fitting workwear with low tear strength, tight sleeves and no hanging parts.



Respirator mask

Protects from hazardous gases, vapors, dust and similar materials and media.



Safety boots

Protect feet from crushing, falling items and slipping.



Use ear protection

Protects from auditory damage due to noise.

3 Transport, scope of supply and storage

3.1 Transport

! NOTICE!

Incorrect Transport

Incorrect Transport can cause property damage.

- Protect Regulator from moisture.
- Protect Regulator from vibrations.
- Protect Regulator from falling down.
- Transport temperature: -30°C to 60°C

3.2 Unpacking

EX DANGER!

Electrostatically charged plastic films and foils in potentially explosive areas

The foil and the product can charge electrostatically at the time of the unpacking. Electrostatic discharge can cause sparks that in explosive atmosphere can cause a fire or an explosion. Serious injury and death could be the consequence.

- Unpack product outside Ex zones.
- Discharge the product.
- Dispose packaging outside of the Ex zone in accordance with the regulation or store properly for a later return.

3.3 Scope of delivery

The scope of supply includes the following components:

- Regulator

Inspect delivery on receipt for completeness and integrity.

Report defects immediately ↪ "Hotline and Contact".

3.4 Handling of packaging material

🌱 ENVIRONMENT!

Incorrect disposal

Incorrectly disposed packaging material can damage environment.

- Dispose of material no longer required in an environment-friendly manner.
- Observe local disposal specifications.

3.5 Storage

Storage provisions:

- Do not store outdoors.
- Store Regulator only when dry.
- Store in a dust-free place.
- Do not expose to aggressive media.
- Protect from solar radiation.
- Avoid mechanical vibrations.
- Temperature: 10°C to 40°C
- Relative humidity: 35% to 90%

4 Assembly

4.1 Requirements for the Installation point.

- The control air supply to the regulator must allow to be disconnected and secured from being switched on again. It must be possible to close the lines upstream of the regulator.
- The control air must be controllable.
- Lines, seals and screw connections must be designed to conform to the requirements of the regulator ↪ 11.5 "Operating values".
- The regulator must be permanently fixed.
- The regulator must be grounded.
- A safety distance of 0.25cm/kV from the high voltage must be kept.

4.2 Assembly

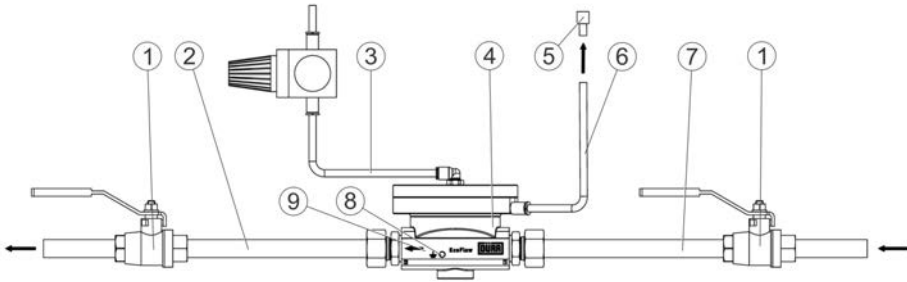

Fig. 2: Assembly drawing

Personnel:

- Mechanic
- + additional qualification explosion protection

Protective equipment:

- Protective workwear
- Eye protection
- Protective gloves
- Safety boots

Observe the following at assembly:

- Ensure a non-explosive atmosphere.
- Install the regulator before the applicator.
- Alignment: Lid on top, regulator housing at bottom
- Provide pressure switch (5) if necessary. The pressure switch is integrated in the control and issues a pressure message to the control if leakage occurs. In the event of leakage, the control system switches the system off
- Flow direction
- Install and fix the regulator through the pipelines or using a bracket ↪ 12.2 "Accessories".
- Provide cutoff valves (1) if necessary.
- If necessary, install filter before the regulator.
- Maximum tightening torque for material inlet and material outlet:
 - 90Nm
- Observe maximum tightening torque for all screw connections
- Check the lines regularly. Vibrations can cause screw connections to come off loose.
- Ensure pressure monitoring. Install pressure gage (9) if necessary ↪ 4.3 "Assemble pressure gage".

1. Screw the material supply line (7) into the material inlet.
2. Screw the material discharge line (2) into the material outlet.
3. Screw the leakage line (6) into the leakage connection.



The leakage line also prevents dirt from entering the regulator housing through the leakage connection.

4. Connect the control air (3) ↪ 11.5 "Operating values".

Ground the regulator

Personnel:

- Electrician
- + additional qualification explosion protection

Protective equipment:

- Protective workwear
- Safety boots

1. Ground the regulator (4) via its grounding connection (8).

4.3 Assemble pressure gage



Fig. 3: Pressure gage



Only N26210007 and N26210008

Personnel:

- Mechanic
- + additional qualification explosion protection

Protective equipment:

- Eye protection
- Protective workwear
- Protective gloves
- Safety boots

A pressure gage can be installed for checking the material pressure. An adapter (1) will facilitate the screw fixing.

1. Screw pressure gage onto the adapter (1).
2. Align pressure gage such that it can be read easily.
3. Test function and tightness of the pressure gage.



On the back of the regulator, a sealing screw seals the bore of the pressure gage. If the pressure gage is installed on the other side, interchange sealing screw and adapter.

5 Commissioning

5.1 Safety Instructions



WARNING!

Danger from harmful or irritant substances

Serious injuries or death can result if you come into contact with dangerous fluids or steam.

- Regulator Check regularly for leakage. Observe local regulations and maintenance schedule.
- Ensure that the forced ventilation is operational.
- Follow the safety data sheet.
- Wear specified protective clothing.
- Avoid contact (e.g. with eyes, skin).



WARNING!

Squirting material

Escaping compressed material can cause serious injury.

- Check the product for leakage before commissioning.
- Put the product into operation only if the connections are made professionally.



WARNING!

Sparks due to electrostatic discharge

If the regulator is not grounded, there can be an electrostatic charge on the the regulator. Electrostatic discharge can cause sparks that in explosive atmosphere can cause a fire or an explosion. Serious injury and death could be the consequence.

- Ground Regulator as specified.
- Before carrying out any work, make sure that there is no explosive atmosphere.



NOTICE!

Material damage due to dry run

If the regulator is operated without material, it wears out faster.

- Always operate a regulator with material.



NOTICE!

Material damage due to unsuitable pipe connections

The pipeline or a bracket supports the regulator. A loose pipeline can make the regulator vibrate during operation. It can loosen screw connections. Paint or solvent can leak out. This results in property damage.

- Dimension the lines to conform to the regulator requirements .
- If necessary, support the regulator by using a bracket ↪ 12.2 "Accessories".

5.2 Commissioning



The regulator is commissioned along with the system.

Personnel:

- Mechanic
- + additional qualification explosion protection

Protective equipment:

- Protective gloves
- Safety boots
- Use ear protection
- Protective workwear

Requirements:

- Regulator connections are properly assembled ↪ 4.2 "Assembly".
- Leakage test has been conducted.

1. Set control air pressure to 0bar.

2.



The difference between input pressure and material pressure must not exceed 7bar.

Adjust the input pressure so that it is at least 1bar above the desired material pressure.

3. Open ball valves in the supply lines.
4. Open the sampling point.
5. Increase control air pressure slowly until material starts flowing.
6. Leave the sampling point opened until the material escapes without air.
7. Increase control air pressure, based on the following characteristic curve until the required material pressure is reached.

Characteristic curves

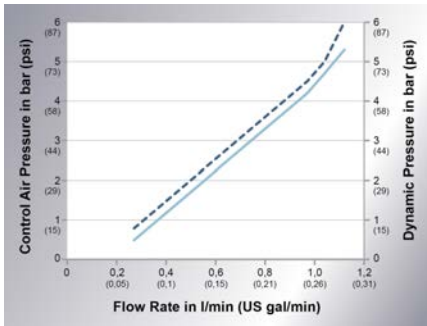

Fig. 4: Characteristic curve (N26210002/ N26210007)

- Dynamic pressure
- Control air pressure

Specification of the characteristic curves:

- Material: Mobil DTE24
- Viscosity: 32mPa*s
- Shield: 1mm
- Input pressure: p = 6bar

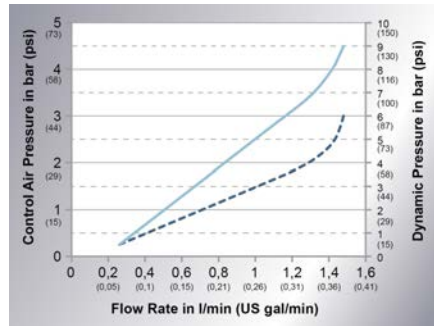

Fig. 5: Characteristic curve (N26210003/ N26210008)

- Dynamic pressure
- Control air pressure

Specification of the characteristic curves:

- Material: Mobil DTE24
- Viscosity: 32mPa*s
- Shield: 1mm
- Input pressure: p = 10bar

6 Operation

6.1 Safety recommendations



WARNING!

Sparks due to electrostatic discharge

If the grounding cable is removed during operation, it can cause electrostatic induction. Electrostatic discharge can cause sparks that in explosive atmosphere can cause a fire or an explosion. Serious injury and death could be the consequence.

- Do not remove grounding cable during operation.

**WARNING!****Risk of injury due to escaping material and compressed air**

Escaping compressed material can cause serious injury.

Before carrying out any work:

- Disconnect the system, in which the regulator is installed, from compressed air and material supply.
- Secure the system against being switched on again.
- Depressurize the lines.

**NOTICE!****Hardening material**

If the material in the product hardens, the product will be damaged or destroyed.

- Note curing time. ↪ 11.10 "Material specification"
- Rinse product ↪ 6.2 "Rinsing" e.g. for:
 - Production interruptions
 - Production end

**NOTICE!****Material damage due to unsuitable rinsing agent**

If the rinsing agent reacts chemically with the components or the material, components get damaged.

- Use only the rinsing agents that are compatible with the components and the material.
- Refer to safety data sheet of material manufacturer.

The regulator must be rinsed.

- After end of work
- Before every change of material
- Prior to cleaning
- Prior to dismantling
- Before a long time of non-use
- Before placing in storage



Rinsing intervals depend on the material used.

1. Rinse regulator with low pressure. Possibly. Use rinsing equipment.

6.2 Rinsing

Personnel:

- Mechanic
- + additional qualification explosion protection

Protective equipment:

- Protective workwear
- Eye protection
- Safety boots

6.3 Relieving pressure

Personnel:

- Mechanic
- + additional qualification explosion protection

Protective equipment:

- Protective gloves
- Safety boots
- Use ear protection
- Protective workwear

1. Rinse regulator ↪ 6.2 "Rinsing".
2. Close the ball valve on the material supply line.
 - ⇒ Secure ball valve against reconnection while working on it.
3. Open the sampling point.
4. Set control air pressure to 5 to 6bar.
 - ⇒ The regulator opens. Pressure relief in the system takes place.
5. Set control air pressure to 0bar.
 - ⇒ The regulator closes. The system is now depressurized.
6. Disassemble regulator ↪ 10.2 "Disassembly".

7 Cleaning

7.1 Safety recommendations



WARNING!

Danger of fire and explosion

Flammable coating materials and their detergents and cleaning agents can cause a fire or an explosion.

- Ensure that the flashpoint of the fluid is at least 15K above the ambient temperature.
- Only electrically conductive containers may be used for the cleaning fluid. Containers must be grounded.
- Note explosion group of the fluid.
- Follow the safety data sheet.
- Ensure that forced ventilation and fire protection equipment are in operation.
- Do not use sources of ignition and open light.
- Do not smoke.
- Ground Regulator.



WARNING!

Danger from harmful or irritant substances

Serious injuries or death can result if you come into contact with dangerous fluids or steam.

- Regulator Check regularly for leakage. Observe local regulations and maintenance schedule.
- Ensure that the forced ventilation is operational.
- Follow the safety data sheet.
- Wear specified protective clothing.
- Avoid contact (e.g. with eyes, skin).

! NOTICE!

Unsuitable cleaning agents

Unsuitable cleaning agents can damage the product.

- Only use cleaning agents approved by the material manufacturer.
- Follow safety data sheets.
- Place heavily soiled components in a cleaning bath.
 - Only place those parts in the cleaning bath, which are suitable for the cleaning bath.
 - Use only electrically conductive containers.
 - Ground the container.
 - Do not use ultrasound baths.

! NOTICE!

Unsuitable Cleaning Tools

Unsuitable cleaning tools can cause damage.

- Only use cloths, soft brushes and paintbrushes.
- Do not use abrasive cleaning tools.
- Do not use compressed air for cleaning.
- Do not use any thinner spray guns.
- Do not use high pressure for cleaning agents.

7.2 Cleaning

Personnel:

- Cleaning staff
- + additional qualification explosion protection

Protective equipment:

- Protective workwear
- Respirator mask
- Eye protection

- Protective gloves
- Safety boots

Requirements:

- Regulator has been purged ↪ 6.2 “Rinsing”
 - System has been depressurized ↪ 6.3 “Relieving pressure”.
1. Clean the regulator carefully using a piece of cloth.

8 Maintenance

8.1 Safety recommendations

EX WARNING!

Unsuitable tools in explosive areas

Tools that do not have Ex approval can generate sparks and cause a fire or an explosion in Ex zones. It can cause serious injuries or death.

- If possible, carry out cleaning and maintenance work outside the Ex zones.
- For work within the Ex zone, use tools with the corresponding Ex labeling.

! WARNING!

Risk of injury due to escaping material and compressed air

Escaping compressed material can cause serious injury.

Before carrying out any work:

- Disconnect the system, in which the regulator is installed, from compressed air and material supply.
- Secure the system against being switched on again.
- Depressurize the lines.

 **WARNING!****Sparks due to electrostatic discharge**

If the regulator is not grounded, there can be an electrostatic charge on the the regulator. Electrostatic discharge can cause sparks that in explosive atmosphere can cause a fire or an explosion. Serious injury and death could be the consequence.

- Ground Regulator as specified.
- Before carrying out any work, make sure that there is no explosive atmosphere.

 **WARNING!****Danger from harmful or irritant substances**

Serious injuries or death can result if you come into contact with dangerous fluids or steam.

- Regulator Check regularly for leakage. Observe local regulations and maintenance schedule.
- Ensure that the forced ventilation is operational.
- Follow the safety data sheet.
- Wear specified protective clothing.
- Avoid contact (e.g. with eyes, skin).

 **WARNING!****Danger of fire and explosion**

Flammable coating materials and their detergents and cleaning agents can cause a fire or an explosion.

- Ensure that the flashpoint of the fluid is at least 15K above the ambient temperature.
- Only electrically conductive containers may be used for the cleaning fluid. Containers must be grounded.
- Note explosion group of the fluid.
- Follow the safety data sheet.
- Ensure that forced ventilation and fire protection equipment are in operation.
- Do not use sources of ignition and open light.
- Do not smoke.
- Ground Regulator.

 **WARNING!****Unsuitable replacement parts in explosive areas**

Replacement parts not compliant with the specifications of the ATEX guidelines can cause explosions in an explosive atmosphere. Serious injury and death could be the consequence.

- Use exclusively original replacement parts.

! NOTICE!

Damage due to improper maintenance work

Carrying out maintenance work that is not described in this instructions manual can result in errors in assembly and cause material damage.

- Only carry out work mentioned in this instructions manual.

! NOTICE!

Material damage due to worn out components

Worn out components can damage the product.

- Observe the maintenance intervals ↪ 8.2 "Maintenance schedule".

 **ENVIRONMENT!**

Environmental damage caused by improper handling

Leaked out operating and auxiliary materials are a threat to the environment.

- Use suitable collector trays during servicing and maintenance work.
- Dispose of operating and auxiliary materials according to the disposal provisions in force.
- In case of doubt, refer to the local disposal authorities.

8.2 Maintenance schedule



If a maintenance assistant is used in the system visualizer, the maintenance intervals of the maintenance assistant are valid.

The maintenance intervals given below are based on experiential values. Adjust maintenance intervals individually if necessary.

Interval	Maintenance work
weekly	Check condition and tightness of the regulator, the connections and lines. Check air leak and leakage of liquids.
monthly	Clean regulator ↪ 7.2 "Cleaning".
semi-annually	Check membrane in contact with material (10), membrane chuck (11), O-ring (15), ball (16), compression spring (17) and sealing rings (18, 19), and replace if defective ↪ 8.3 "Dismantling".
annually	Check screw connections and fastening.
every 2 years	Check membrane (4), replace if necessary ↪ 8.3 "Dismantling".

8.3 Dismantling

Personnel:

- Mechanic
- + additional qualification explosion protection

Protective equipment:

- Protective gloves
- Eye protection
- Safety boots
- Protective workwear

Requirements:

- Regulator has been purged ↪ 6.2 “Rinsing”.
- Regulator has been disassembled ↪ 10.2 “Disassembly”.

You must dismantle the regulator to be able to perform maintenance work and to replace components. The requirement is a clean working place in a workshop.

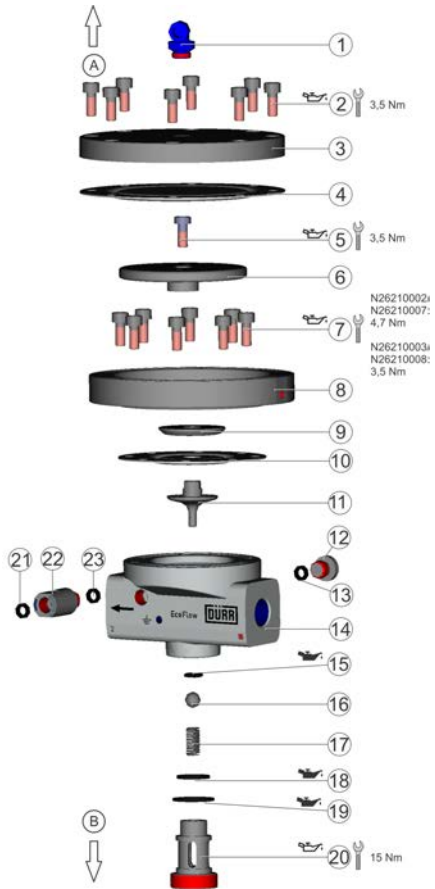

Fig. 6: Exploded-view drawing

- Molykote TP-42
- Klüber Syntheso GLEP 1

1. Clamp the regulator with the control side (A) upward into a vise.



Use protective jaws.

2. Mark the lid (3), the spacer ring (8) and the housing (14) with a line.



Use line as reference at assembly. This will ensure all connections are aligned correctly.

3. Unscrew control air connection (1).
4. Unscrew cheese-head screws with a hexagon socket (2).
5. Remove housing lid (3).
6. Mark the top side of the first membrane (4).
7. Remove the first membrane (4).
8. Hold the pressure disc (6) using a face spanner.
9. Unscrew the screw (5) from the pressure disc (6)..
10. Remove pressure disc (6).
11. Unscrew cheese-head screws (7).
12. Remove the spacer ring (8).
13. Mark the top side of the bottom membrane (10).
14. Remove pressure disc (9), bottom membrane (10) and membrane chuck (11).
15. Remove the regulator from the vise and clamp it again with the material side (B) facing up.
16. Release sealing insert (20).
17. Remove sealing rings (19) and (18).
18. Remove compression spring (17), ball (16) and O-ring (15).

19. In the case of regulators with pressure gage connection: Unscrew sealing screw (12) and remove sealing ring (13).
20. Unscrew adapter (22) and remove sealing rings (21) and (23).
21. Clean, check and replace all components if damaged. Generally replace all seals.

8.4 Assembly



Lubricate threads and seals before assembly.

Personnel:

- Mechanic
- + additional qualification explosion protection

Protective equipment:

- Protective workwear
- Protective gloves
- Safety boots

1. Clamp the regulator housing (14) with the material side (B) upwards into a vise.





Use protective jaws.

2. Steps 2 - 4 only N26210007 and N26210008: Insert the sealing ring (13) into the regulator housing (14) and screw the sealing screw (12) in.
3. Insert the sealing ring (21) into the adapter (22).
4. Insert the sealing ring (23) into the regulator housing (14) and screw the adapter (22) in.

5. Lightly grease the new O-ring (15) and insert it into the regulator housing (14).
 6. Insert ball (16) into the regulator housing (14).
 7. Insert sealing rings (18) and (19) into the regulator housing (14).
 8. Lightly grease the compression spring (17) and insert it into the sealing insert (20).
 9. Screw the sealing insert (20) into the regulator housing (14).
 - Tightening torque: 15Nm
 10. Remove the regulator from the vise and clamp it again with the control side (A) facing upwards.
 11.

 If the membrane is not replaced, assembly the membrane again with the marking upward. The membrane has been stretched out on one side during operation.

Place bottom membrane (10) and pressure disc (9) on the membrane chuck (11).
 12. Place membrane chuck (11), bottom membrane (10) and pressure disc (9) on the regulator housing (14).
 13. Place spacer ring (8) on the bottom membrane (10), ensuring that the screw holes are one above the other.
 14. Use cheese-head screws (7) to screw spacer ring (8) and bottom membrane (10) onto the regulator housing (14).
 - Tightening torque N26210002 / N26210007: 4.7Nm
 - Tightening torque N26210003 / N26210008: 3.5Nm
 15. Insert pressure disc (6) onto the membrane chuck (11). Ensure that the key surface of the membrane chuck (11) has latched in place in the pressure disc (6).
 16. Hold the pressure disc (6) using a face spanner.
 17. Screw pressure disc (6) onto the membrane chuck (11) using the screw (5).
 - Tightening torque: 3.5Nm
 18. Check the top membrane (4) for damage. Replace, if necessary.

 If the membrane is not replaced, assembly the membrane again with the marking upward. The membrane has been stretched out on one side during operation.
 19. Place top membrane (4) onto the spacer ring (8).
 20. Place housing lid (3) onto the top membrane (4).
 21. Tighten the cheese-head screws (2) in a crosswise sequence.
 - Tightening torque: 3.5Nm
 22. Screw the control air connection (1) onto the housing lid (3).
-  Perform operation and tightness check before re-commissioning.

9 Faults

9.1 Defects table

For troubleshooting you have to (partly) dismantle the regulator ↪ 8.3 “Dismantling”. If faults cannot be remedied: ↪ “Hotline and Contact”.

Fault description	Cause	Remedy
Poor regulation	Ball, O-ring or compression spring are worn out	Replace ball, O-ring and compression spring.
	Membrane damaged	Replace membrane.
	Metal membrane chuck is damaged	<ul style="list-style-type: none"> ▪ Replace the membrane chuck. ▪ Check membrane for damage. ▪ If membrane is damaged, replace membrane.
	Compression spring broken	Replace compression spring.
	Foreign bodies between pressure disc and spacer ring	Seal leakage connection against ingress of foreign bodies.
	Air supply fluctuates.	Check air regulation. Repair if necessary.
Air leaks from the leakage connection or between housing and lid	Membrane damaged	Replace membrane.
	Scoring in lid or spacer ring	Replace lid or spacer ring.
Material leaks from housing	Membrane damaged	Replace membrane.
	Pressure disc and spacer incorrectly assembled	Assemble pressure disc and spacer correctly.
	Cheese-head screws or sealing insert tightened with incorrect torque	Tighten cheese-head screws or sealing insert with the correct torque.
Whistling sound from regulator.	Regulator set incorrectly	<ul style="list-style-type: none"> ▪ Checking pressure settings. ▪ Change parameters.

10 Disassembly and Disposal

10.1 Safety recommendations



WARNING!

Risk of injury due to escaping material and compressed air

Escaping compressed material can cause serious injury.

Before carrying out any work:

- Disconnect the system, in which the regulator is installed, from compressed air and material supply.
- Secure the system against being switched on again.
- Depressurize the lines.



WARNING!

Unsuitable tools in explosive areas

Tools that do not have Ex approval can generate sparks and cause a fire or an explosion in Ex zones. It can cause serious injuries or death.

- If possible, carry out cleaning and maintenance work outside the Ex zones.
- For work within the Ex zone, use tools with the corresponding Ex labeling.



WARNING!

Danger from harmful or irritant substances

Serious injuries or death can result if you come into contact with dangerous fluids or steam.

- Regulator Check regularly for leakage. Observe local regulations and maintenance schedule.
- Ensure that the forced ventilation is operational.
- Follow the safety data sheet.
- Wear specified protective clothing.
- Avoid contact (e.g. with eyes, skin).

10.2 Disassembly

Personnel:

- Mechanic
- + additional qualification explosion protection

Protective equipment:

- Protective workwear
- Eye protection
- Protective gloves
- Safety boots

1. Rinse regulator ↪ 6.2 "Rinsing".
2. Close material supply line with valve and secure against being switched on again.
3. Depressurize the line ↪ 6.3 "Relieving pressure".
4. Loosen cap nut of material supply line.
5. Loosen cap nut of material discharge line.
6. Unscrew transparent hose from leakage connection.

7. Unscrew control air line from connection for control air.
8. Remove the regulator.
9. Possibly. Disassemble pressure gage.

10.3 Disposal



ENVIRONMENT!

Improper waste disposal

Improper waste disposal threatens the environment and prevents re-use and recycling.

- Clean components before their disposal.
- Always dispose of components in accordance with their characteristics.
↳ 11.8 “Materials used”
- Collect leaked out utilities and auxiliaries completely.
- Dispose of work equipment soaked in coating materials or operating substances according to the disposal provisions in force.
- Dispose of utilities and auxiliaries according to the disposal provisions in force.
- In case of doubt, refer to the local disposal authorities.

11 Technical data

11.1 Dimensions and weight

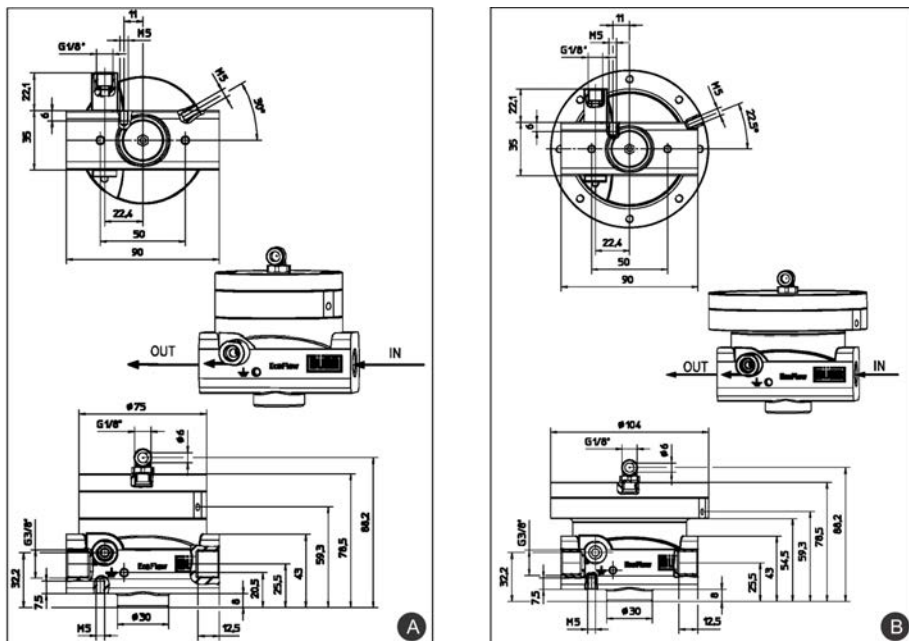

Fig. 7: Dimensions (example N26210007 (A), N26210008 (B))

Detail	N26210002 / N26210007 (A)	N26210003 / N26210008 (B)
Total length	90 mm	90 mm
Height	88.2 mm	88.2 mm
Diameter	75 mm	104 mm
Weight	1.4 kg	1.7 kg

11.2 Connections

Connection	Value
Material outlet connection	G3/8"

Connection	Value
Material inlet connection	G3/8"

Connection	Value
Control air connection	G1/8"
Pressure gage connection (only N26210007 / N26210008)	G1/8"

11.3 Operating conditions

Detail	Value
Operating temperature, min.	15°C
Operating temperature, max.	35°C
Ambient temperature, min.	15°C
Ambient temperature, max.	40°C

11.5 Operating values

Detail	N26210002 / N26210007 (A)	N26210003 / N26210008 (B)
Control air pressure, min.	1bar	1bar
Control air pressure, max.	8bar	8bar
Input pressure, max.	20 bar	20 bar
Control range	0.5 to 5bar	0.5 to 15bar
Flow rate, max.	8L/min	8L/min

11.6 Compressed air quality

- Purity classes following ISO 8573-1::2010
1:3:1 1:4:1
- Limitations for purity class 4 (pressure
dew point max.):
 - $\leq -3^{\circ}\text{C}$ at 7bar absolute
 - $\leq +1^{\circ}\text{C}$ at 9bar absolute
 - $\leq +3^{\circ}\text{C}$ at 11bar absolute

11.4 Emissions

Detail	Value
Noise	An imperfectly set regulator can emit whistling sounds.

11.7 Type plate

Technical data

The type plate is also on the housing lid and features the following data:

- Product name
- Material number
- Year of manufacture
- Serial number
- Ex labeling
- Maximum air pressure
- Maximum material pressure
- Manufacturer
- CE labeling
- QR Code

11.8 Materials used

Materials used

Component	Material
Lid, spacer ring	Aluminum
Regulator housing	Stainless steel
Parts in contact with material	Stainless steel
Membrane	PTFE
Ball	Ceramic
Seals	POM

11.9 Operating and auxiliary materials

Material	Specification
Screw connections lubricant	Molykote TP-42
Seal lubricant	Klüber Syntheso GLEP 1

11.10 Material specification

Suitable Material:

- Flammable fluid coating materials of the explosion group IIA and their approved cleaning agents
- Non-flammable fluid coating materials and their approved detergents

Specification:

- Vapor pressure ≤ 0.5 bar above atmosphere
- Ignition temperature $> 50^{\circ}\text{C}$
- Temperature $\leq 35^{\circ}\text{C}$, always 15K below flashpoint

Viscosity

Detail	Value
Viscosity, min.	10mPa S
Viscosity, max.	250mPa S

12 Replacement parts and accessories

12.1 Replacement parts

Item numbers relate to the ☞ 8.3 "Dismantling".

Item	Denomination	Quantity	Order No.
1	Control air connection	1	-
2	Cheese-head screws M5x12 D6912	8	-
3	Regulator cap	1	-
4	Membrane (N26210002 / N26210007) Membrane (N26210003 / N26210008)	1	M08510060 M08510061
5	Cylinder screw M5x12	1	-
6	Pressure disc	1	-
7	Cheese-head screws M5x16 (N26210002 / N26210007) Cheese-head screws M5x12 (N26210003 / N26210008)	8	-
8	Spacer ring	1	-
9	Pressure disc	1	-
10	Membrane D75	1	M08510059
11	Membrane chuck	1	-
12	Sealing screw (only N26210007 / N26210008)	1	-
13	Sealing ring (only N26210007 / N26210008)	1	M08010175
14	Regulator housing	1	-
15	O-ring 7.2x1.8	1	Included in KIT N26960007
16	Ball D8	1	Included in KIT N26960007
17	Compression spring	1	Included in KIT N26960007
18	Sealing ring D14.1	1	Included in KIT N26960007
19	Sealing ring D21.2	1	Included in KIT N26960007
20	Sealing insert	1	-
21	Sealing ring (only N26210007 / N26210008)	1	M08010175

Item	Denomination	Quantity	Order No.
22	Adapter (only N26210007 / N26210008)	1	-
23	Sealing ring (only N26210007 / N26210008)	1	M08010175

12.2 Accessories



Fig. 8: Angle

Item	Denomination	Quantity	Order No.
1	Angle bracket	1	M19023638

12.3 Order



WARNING!

Unsuitable replacement parts in explosive areas

Replacement parts not compliant with the specifications of the ATEX guidelines can cause explosions in an explosive atmosphere. Serious injury and death could be the consequence.

- Use exclusively original replacement parts.



WARNING!

Unsuitable replacement parts

Replacement parts of third-party suppliers may possibly not be able to hold the loads. Serious injury and death could be the consequence.

- Use exclusively original replacement parts.

Ordering replacement parts, tools and accessories as well as information on products that are listed without order number ↗ “Hotline and Contact”.



LEADING IN
PRODUCTION
EFFICIENCY

 Dürr Systems AG
Application Technology
Carl-Benz-Str. 34
74321 Bietigheim-Bissingen
Germany

 Phone +49 7142 78-0

 www.durr.com

Translation of the original operation manual
MRE00008EN, V02

The reproduction and distribution of this document, use and communication of its contents are not permitted without express written approval. Offenders will be liable for damages. All rights in the event of a patent grant or design registration are reserved.

© Dürr Systems AG 2016