

LEADING IN  
PRODUCTION  
EFFICIENCY



## EcoFlow LPF P

### Low Pressure Regulator Flow

#### Operation manual

MRE00004EN, V04

N26010101

### Information about the document

This document describes the correct handling of the product.

- Read the document prior to every activity.
- Prepare the document for the application.
- Pass on the product only together with the complete documentation.
- Always follow safety instructions, handling instructions and specifications of every kind.
- Illustrations can deviate from the technical construction.

### Validity range of the document

This document describes the following products:

N26010101  
**EcoFlow LPF P 7 2.5**  
G1/8" SST



### Hotline and Contact

If you have queries or would like technical information, please contact your dealer or sales partner.

## TABLE OF CONTENTS

<b>1</b>	<b>Product overview</b> .....	<b>4</b>	<b>8</b>	<b>Maintenance</b> .....	<b>15</b>
	1.1 Overview.....	4	8.1	Safety recommendations.....	15
	1.2 Short description.....	4	8.2	Maintenance schedule.....	17
<b>2</b>	<b>Safety</b> .....	<b>4</b>	8.3	Dismantling.....	17
	2.1 Presentation of Notes.....	4	8.4	Assembly.....	19
	2.2 Intended Use.....	5	<b>9</b>	<b>Faults</b> .....	<b>20</b>
	2.3 Residual risks.....	6	9.1	Defects table.....	20
	2.4 Property damage.....	6	<b>10</b>	<b>Disassembly and Disposal</b> .....	<b>21</b>
	2.5 Staff qualification.....	6	10.1	Safety recommendations....	21
	2.6 Personal protective equip- ment.....	7	10.2	Disassembly.....	21
<b>3</b>	<b>Transport, scope of supply and storage</b> .....	<b>8</b>	10.3	Disposal .....	22
	3.1 Transport.....	8	<b>11</b>	<b>Technical data</b> .....	<b>22</b>
	3.2 Unpacking.....	8	11.1	Dimensions and weight.....	22
	3.3 Scope of delivery.....	8	11.2	Connections.....	22
	3.4 Handling of packaging material.....	8	11.3	Operating conditions.....	23
	3.5 Storage.....	8	11.4	Emissions.....	23
<b>4</b>	<b>Assembly</b> .....	<b>8</b>	11.5	Operating values.....	23
	4.1 Requirements for the Installation point.....	8	11.6	Compressed air quality.....	23
	4.2 Assembly.....	9	11.7	Type plate.....	23
<b>5</b>	<b>Commissioning</b> .....	<b>10</b>	11.8	Materials used.....	23
	5.1 Safety Instructions.....	10	11.9	Operating and auxiliary materials.....	23
	5.2 Commissioning.....	11	11.10	Material specification.....	24
<b>6</b>	<b>Operation</b> .....	<b>12</b>	<b>12</b>	<b>Replacement parts, tools and accessories</b> .....	<b>24</b>
	6.1 Safety recommendations.....	12	12.1	Replacement parts.....	24
	6.2 Rinsing.....	12	12.2	Tools.....	25
	6.3 Relieving pressure.....	13	12.3	Accessories.....	25
<b>7</b>	<b>Cleaning</b> .....	<b>13</b>	12.4	Order.....	26
	7.1 Safety recommendations .....	13			
	7.2 Cleaning.....	14			

## 1 Product overview

### 1.1 Overview

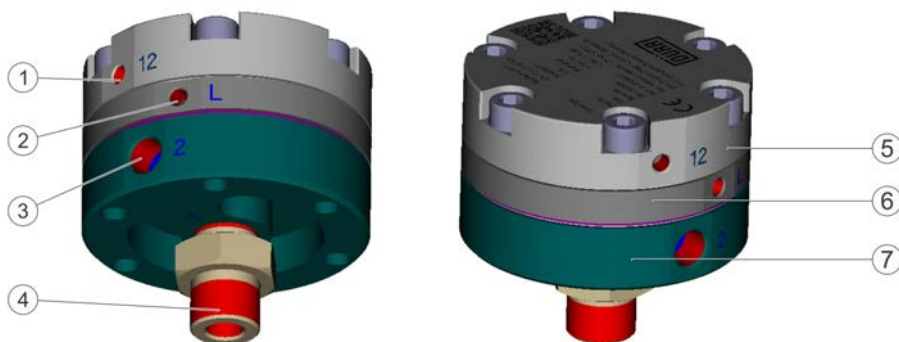

Fig. 1: Product overview

- 1 Connection for control air
- 2 Leakage connection
- 3 Material outlet
- 4 Material inlet

- 5 Housing cover
- 6 Spacer ring with membranes
- 7 Regulator housing

### 1.2 Short description

The low pressure controller (hereafter called “Regulator”) reduces the pressure in the supply line of an application system by means of the control air to the required material pressure. It protects the downstream devices from pressure surges and pulsations.

## 2 Safety

### 2.1 Presentation of Notes

The following notes can appear in this instruction:



#### **DANGER!**

High risk situation that can lead to serious injuries or death.



**WARNING!**

Medium risk situation that can lead to serious injuries or death.



**CAUTION!**

Low risk situations that can lead to minor injuries.



**NOTICE!**

Situations that can lead to material damage.



**ENVIRONMENT!**

Situations that can lead to environmental damage.



Additional information and recommendations.

**2.2 Intended Use**

**Use**

The low pressure controller **EcoFlow LPF** serves exclusively for material pressure regulation in the supply line of application systems.

The low pressure controller is approved for use in explosive areas of Ex zones 1 and 2.



The low pressure controller for fluids does not fall in one of the categories I-IV of the pressure devices guidelines. The low pressure controller is designed and manufactured as specified in article 3 para 3 of 97/23/EC from 2016 onwards in article 4 para 3 of 2014/68/EU.

**Misuse**

If used improperly, it can cause serious injuries.

Examples of wrong use are:

- Use in explosive areas Ex zone 0
- Use of unapproved materials
- Making conversions or changes on your own

**EX labeling**



II 2G Ex h IIA T6 Gb X

- II - Device group II: all areas except mining
- 2G - Device category: 2 (for gaseous atmosphere)
- h - Ignition protection category for non-electrical devices
- IIA - Explosion group
- T6 - Temperature class
- Gb - Device category and device protection level: Gb (zone 1)
- X - Restriction: The device is configured for operation in an ambient temperature of 15°C to 40°C.

## 2.3 Residual risks

### Explosion

Sparks, open flames and hot surfaces can cause explosions in explosive atmospheres. Serious injury and death could be the consequence.

- Before carrying out any work on the product, ensure a non-explosive atmosphere.
- Do not use sources of ignition and open light.
- Do not smoke.
- Ground the product.
- Wear suitable protective equipment.

Flammable coating materials and their detergents and cleaning agents can cause a fire or an explosion.

- Ensure that the flashpoint of the fluid is at least 15K above the ambient temperature.
- Observe explosion group of the coating materials and their detergents and cleaning agents.
- Follow the safety data sheet.
- Ensure that technical ventilation and fire protection equipment are in operation.
- Do not use sources of ignition and open light.
- Do not smoke.
- Ground the product.
- Wear suitable protective equipment.

### Danger due to escaping material

Material escaping under pressure can cause serious injuries.

Before the product:

- Switch off the system.
- Disconnect the system from energy and material supply.
- Depressurize the lines.
- Secure the system against switching on again.

## 2.4 Property damage

### Hardening material

If the material in the product hardens, the product will be damaged or destroyed.

- 1K material: Note curing time ↪ 11.10 "Material specification"
- 2K material: Observe pot time ↪ 11.10 "Material specification"
- Purge product ↪ 6.2 "Rinsing", e.g. in the case of:
  - Production interruptions
  - Production end

## 2.5 Staff qualification



### WARNING!

#### Inadequate qualification

Wrong estimation of dangers can cause serious injury or death.

- Only sufficiently qualified persons may execute all work.
- Some work requires additional qualification. Additional qualifications of specialized personnel are marked with a "+".

This document is intended for qualified personnel in industry and craftsmanship.

#### Cleaning staff

The cleaning staff receives regular instructions from the operator about the following contents:

- Using the product
- Handling cleaning tools
- Handling cleaning agents
- Technical Measures for occupational safety and health

#### Electrician

Electricians assemble, install, service and repair electrical systems in a professional manner.

Furthermore, electrical engineers have the following knowledge:

- Guidelines, Standards and Rules of Engineering
- Local conditions
- Electrical Systems and Their Loading Limits
- Technical Measures for occupational safety and health

### Mechanic

The mechanic is trained specifically for the field of work in which he works.

Furthermore, he has the following knowledge:

- Guidelines, Standards and Rules of Engineering
- Local conditions
- Technical Measures for occupational safety and health

The mechanic is responsible for the following activities on equipment and components:

- Assembly
- Waiting
- Maintenance
- Disassembly

### + additional qualification explosion protection

In addition to the knowledge of the various specialist fields, the mechanic has knowledge of regulations and safety measures when working in potentially explosive areas.

Dürr Systems offers special product training for ↪ "Hotline and Contact".

## 2.6 Personal protective equipment

When working in explosive areas, the protective clothing, including gloves, must meet the requirements of DIN EN 1149-5. Footwear must meet the requirements of EN ISO 20344 and EN IEC 61340-4-3. The volume resistivity must not exceed  $100\text{M}\Omega$ .

Wear the specified personal protective equipment when working. Provide the following personal protective equipment:



### Eye protection

Protects eyes from dust, paint drops and particles.



### Protective gloves

Protect the hands from:

- mechanical forces
- Thermal forces
- Chemical effects



### Protective workwear

Tight fitting workwear with low tear strength, tight sleeves and no hanging parts.



### Respirator mask

Protects from hazardous gases, vapors, dust and similar materials and media.



### Safety boots

Protect feet from crushing, falling items and slipping.



### Use ear protection

Protects from auditory damage due to noise.

### 3 Transport, scope of supply and storage

#### 3.1 Transport



#### NOTICE!

##### Incorrect Transport

Incorrect Transport can cause property damage.

- Protect Regulator from moisture.
- Protect Regulator from vibrations.
- Protect Regulator from falling down.
- Transport temperature: -30°C to 60°C

#### 3.2 Unpacking



#### DANGER!

##### Electrostatically charged plastic films and foils in potentially explosive areas

The foil and the product can charge electrostatically at the time of the unpacking. Electrostatic discharge can cause sparks that in explosive atmosphere can cause a fire or an explosion. Serious injury and death could be the consequence.

- Unpack product outside Ex zones.
- Discharge the product.
- Dispose packaging outside of the Ex zone in accordance with the regulation or store properly for a later return.

#### 3.3 Scope of delivery

The scope of supply includes the following components:

- Regulator

Inspect delivery on receipt for completeness and integrity.

Report defects immediately ↪ "Hotline and Contact".

#### 3.4 Handling of packaging material



#### ENVIRONMENT!

##### Incorrect disposal

Incorrectly disposed packaging material can damage environment.

- Dispose of material no longer required in an environment-friendly manner.
- Observe local disposal specifications.

#### 3.5 Storage

Storage provisions:

- Do not store outdoors.
- Store Regulator only when dry.
- Store in a dust-free place.
- Do not expose to aggressive media.
- Protect from solar radiation.
- Avoid mechanical vibrations.
- Temperature: 10°C to 40°C
- Relative humidity: 35% to 90%

### 4 Assembly

#### 4.1 Requirements for the Installation point.

- The control air supply to the regulator must allow to be disconnected and secured from being switched on again. It must be possible to close the lines upstream of the regulator.
- The control air must be controllable.
- Lines, seals and screw connections must be designed to conform to the requirements of the regulator ↪ 11.5 "Operating values".
- The regulator must be permanently fixed.
- The regulator must be grounded.
- A safety distance of 0.25cm/kV from the high voltage must be kept.



## 4.2 Assembly

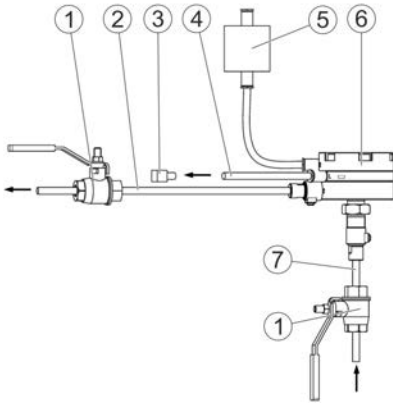

Fig. 2: Assembly drawing (example)

### Personnel:

- Mechanic
- + additional qualification explosion protection

### Protective equipment:

- Protective workwear
- Eye protection
- Protective gloves
- Safety boots

Observe the following at assembly:

- Ensure a non-explosive atmosphere.
- Install the regulator before the applicator.
- Alignment: Lid on top, regulator housing at bottom
- Flow direction
- Provide shut off valves (1).
- Ensure pressure monitoring. Install pressure gage if necessary.
- If necessary, install filter before the regulator.
- Provide pressure switch (3) if necessary. The pressure switch is integrated in the control. In the event of leakage, the pressure switch issues a pressure message to the control system. In the event of leakage, the control system switches the system off.
- Observe maximum tightening torque for all screw connections.
- Vibrations in the pipelines can cause screw connections to come off loose.

1. Fit regulator (6) into the pipeline.
2. Screw cap nut of material supply line (7) to the material inlet.
3. Tighten cap nut of material outflow pipe (2) to material outlet.
4. Connect transparent hose (4) to leakage connection.
5. Connect control air (5) ↪ 11.5 "Operating values".

## Ground the regulator

Personnel:

- Electrician
- + additional qualification explosion protection

Protective equipment:

- Protective workwear
- Safety boots

1. Ground the regulator (6) via the material connection lines.

## 5 Commissioning

### 5.1 Safety Instructions



#### **WARNING!**

##### **Danger from harmful or irritant substances**

Serious injuries or death can result if you come into contact with dangerous fluids or steam.

- Regulator Check regularly for leakage. Observe local regulations and maintenance schedule.
- Ensure that the forced ventilation is operational.
- Follow the safety data sheet.
- Wear specified protective clothing.
- Avoid contact (e.g. with eyes, skin).



#### **WARNING!**

##### **Squirting material**

Escaping compressed material can cause serious injury.

- Check the product for leakage before commissioning.
- Put the product into operation only if the connections are made professionally.



#### **WARNING!**

##### **Sparks due to electrostatic discharge**

If the regulator is not grounded, there can be an electrostatic charge on the the regulator. Electrostatic discharge can cause sparks that in explosive atmosphere can cause a fire or an explosion. Serious injury and death could be the consequence.

- Ground Regulator as specified.
- Before carrying out any work, make sure that there is no explosive atmosphere.



#### **NOTICE!**

##### **Material damage due to dry run**

If the regulator is operated without material, it wears out faster.

- Always operate a regulator with material.

**! NOTICE!**

**Material damage due to unsuitable pipe connections**

The pipeline or a bracket supports the regulator. A loose pipeline can make the regulator vibrate during operation. It can loosen screw connections. Paint or solvent can leak out. This results in property damage.

- Dimension the lines to conform to the regulator requirements .
- If necessary, support the regulator by using a bracket ↪ 12.3 “Accessories”.

5.2 Commissioning

The regulator is commissioned along with the system.

Personnel:

- Mechanic
- + additional qualification explosion protection

Protective equipment:

- Protective gloves
- Safety boots
- Use ear protection
- Protective workwear

Requirements:

- Regulator is properly assembled ↪ 4.2 “Assembly”.
- Regulator connections are properly assembled ↪ 4.2 “Assembly”.
- Screw connections have been tightened.
- Leakage test has been conducted.

1. Set control air pressure to 0bar.

2. Adjust the input pressure of the medium.

The difference between input pressure and regulated pressure must not exceed 7bar. Higher pressure differences may cause premature wear of the sealing seat of the regulator.

3. Slowly open ball valves in the supply lines.
4. Place collecting tray beneath the sampling point.
5. Open the sampling point.
6. Increase control air pressure slowly until material starts flowing.
7. Leave the sampling point opened until the material escapes without air.
8. Increase control air pressure, based on the following characteristic curve until the required material pressure is reached.

**Characteristic curve of the outflow rate**

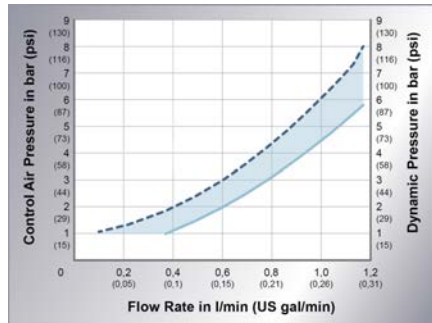

Fig. 3: Characteristic curve of the outflow rate

- Control air pressure
- Work area
- Dynamic pressure

Specifications of the characteristic curve:

- Shield: 1mm
- Material: Mobil DTE 24
- Viscosity: 32mPa S
- Media input pressure: 7 bar

## 6 Operation

### 6.1 Safety recommendations



#### WARNING!

##### Sparks due to electrostatic discharge

If the grounding cable is removed during operation, it can cause electrostatic induction. Electrostatic discharge can cause sparks that in explosive atmosphere can cause a fire or an explosion. Serious injury and death could be the consequence.

- Do not remove grounding cable during operation.



#### WARNING!

##### Risk of injury due to escaping material and compressed air

Escaping compressed material can cause serious injury.

Before carrying out any work:

- Disconnect the system, in which the regulator is installed, from compressed air and material supply.
- Secure the system against being switched on again.
- Depressurize the lines.

#### ! NOTICE!

##### Hardening material

If the material in the product hardens, the product will be damaged or destroyed.

- Note curing time. ↪ 11.10 "Material specification"
- Rinse product ↪ 6.2 "Rinsing" e.g. for:
  - Production interruptions
  - Production end

### 6.2 Rinsing

Personnel:

- Mechanic
- + additional qualification explosion protection

Protective equipment:

- Protective workwear
- Eye protection
- Safety boots

#### ! NOTICE!

##### Material damage due to unsuitable rinsing agent

If the rinsing agent reacts chemically with the components or the material, components get damaged.

- Use only the rinsing agents that are compatible with the components and the material.
- Refer to safety data sheet of material manufacturer.

The regulator must be rinsed.

- After end of work
- Before every change of material
- Prior to cleaning
- Prior to dismantling
- Before a long time of non-use
- Before placing in storage



Rinsing intervals depend on the material used.

1. Rinse regulator with low pressure. Possibly. Use rinsing equipment.

### 6.3 Relieving pressure

Personnel:

- Mechanic
- + additional qualification explosion protection

Protective equipment:

- Protective gloves
- Safety boots
- Use ear protection
- Protective workwear

1. Rinse regulator ↪ 6.2 "Rinsing".
2. Close the ball valve on the material supply line.
  - ⇒ Secure ball valve against reconnection while working on it.
3. Open the sampling point.
4. Set control air pressure to 5 to 6bar.
  - ⇒ The regulator opens. Pressure relief in the system takes place.
5. Set control air pressure to 0bar.

⇒ The regulator closes. The system is now depressurized.

6. Disassemble regulator ↪ 10.2 "Disassembly".

## 7 Cleaning

### 7.1 Safety recommendations



#### WARNING!

##### Danger of fire and explosion

Flammable coating materials and their detergents and cleaning agents can cause a fire or an explosion.

- Ensure that the flashpoint of the fluid is at least 15K above the ambient temperature.
- Only electrically conductive containers may be used for the cleaning fluid. Containers must be grounded.
- Note explosion group of the fluid.
- Follow the safety data sheet.
- Ensure that forced ventilation and fire protection equipment are in operation.
- Do not use sources of ignition and open light.
- Do not smoke.
- Ground Regulator.

**WARNING!****Danger from harmful or irritant substances**

Serious injuries or death can result if you come into contact with dangerous fluids or steam.

- Regulator Check regularly for leakage. Observe local regulations and maintenance schedule.
- Ensure that the forced ventilation is operational.
- Follow the safety data sheet.
- Wear specified protective clothing.
- Avoid contact (e.g. with eyes, skin).

**NOTICE!****Unsuitable cleaning agents**

Unsuitable cleaning agents can damage the product.

- Only use cleaning agents approved by the material manufacturer.
- Follow safety data sheets.
- Place heavily soiled components in a cleaning bath.
  - Only place those parts in the cleaning bath, which are suitable for the cleaning bath.
  - Use only electrically conductive containers.
  - Ground the container.
  - Do not use ultrasound baths.

**NOTICE!****Unsuitable Cleaning Tools**

Unsuitable cleaning tools can cause damage.

- Only use cloths, soft brushes and paintbrushes.
- Do not use abrasive cleaning tools.
- Do not use compressed air for cleaning.
- Do not use any thinner spray guns.
- Do not use high pressure for cleaning agents.

## 7.2 Cleaning

Personnel:

- Cleaning staff
- + additional qualification explosion protection

Protective equipment:

- Protective workwear
- Respirator mask
- Eye protection
- Protective gloves
- Safety boots

Requirements:

- Regulator has been purged ↪ 6.2 “Rinsing”
- System has been depressurized ↪ 6.3 “Relieving pressure”.

1. Clean the regulator carefully using a piece of cloth.

## 8 Maintenance

### 8.1 Safety recommendations

 **WARNING!**

**Unsuitable tools in explosive areas**

Tools that do not have Ex approval can generate sparks and cause a fire or an explosion in Ex zones. It can cause serious injuries or death.

- If possible, carry out cleaning and maintenance work outside the Ex zones.
- For work within the Ex zone, use tools with the corresponding Ex labeling.

 **WARNING!**

**Risk of injury due to escaping material and compressed air**

Escaping compressed material can cause serious injury.

Before carrying out any work:

- Disconnect the system, in which the regulator is installed, from compressed air and material supply.
- Secure the system against being switched on again.
- Depressurize the lines.

 **WARNING!**

**Sparks due to electrostatic discharge**

If the regulator is not grounded, there can be an electrostatic charge on the the regulator. Electrostatic discharge can cause sparks that in explosive atmosphere can cause a fire or an explosion. Serious injury and death could be the consequence.

- Ground Regulator as specified.
- Before carrying out any work, make sure that there is no explosive atmosphere.

 **WARNING!**

**Danger from harmful or irritant substances**

Serious injuries or death can result if you come into contact with dangerous fluids or steam.

- Regulator Check regularly for leakage. Observe local regulations and maintenance schedule.
- Ensure that the forced ventilation is operational.
- Follow the safety data sheet.
- Wear specified protective clothing.
- Avoid contact (e.g. with eyes, skin).

**WARNING!****Danger of fire and explosion**

Flammable coating materials and their detergents and cleaning agents can cause a fire or an explosion.

- Ensure that the flashpoint of the fluid is at least 15K above the ambient temperature.
- Only electrically conductive containers may be used for the cleaning fluid. Containers must be grounded.
- Note explosion group of the fluid.
- Follow the safety data sheet.
- Ensure that forced ventilation and fire protection equipment are in operation.
- Do not use sources of ignition and open light.
- Do not smoke.
- Ground Regulator.

**WARNING!****Unsuitable replacement parts in explosive areas**

Replacement parts not compliant with the specifications of the ATEX guidelines can cause explosions in an explosive atmosphere. Serious injury and death could be the consequence.

- Use exclusively original replacement parts.

**NOTICE!****Damage due to improper maintenance work**

Carrying out maintenance work that is not described in this instructions manual can result in errors in assembly and cause material damage.

- Only carry out work mentioned in this instructions manual.

**NOTICE!****Material damage due to worn out components**

Worn out components can damage the product.

- Observe the maintenance intervals  
↳ 8.2 "Maintenance schedule".

**ENVIRONMENT!****Environmental damage caused by improper handling**

Leaked out operating and auxiliary materials are a threat to the environment.

- Use suitable collector trays during servicing and maintenance work.
- Dispose of operating and auxiliary materials according to the disposal provisions in force.
- In case of doubt, refer to the local disposal authorities.



## 8.2 Maintenance schedule



If a maintenance assistant is used in the system visualizer, the maintenance intervals of the maintenance assistant are valid.

The maintenance intervals given below are based on experiential values. Adjust maintenance intervals individually if necessary.

Interval	Maintenance work
weekly	Check condition and tightness of the regulator, the connections and lines. Check air leak and leakage of liquids.
monthly	Clean ↪ 7.2 "Cleaning".
semi-annually	Check membrane package (7), O-ring (10), sealing ring (9 and 14), ball (11) and spring (12), and replace if defective ↪ 8.3 "Dismantling".
annually	Check screw connections. Check fastening.
every 2 years	Check custom fitting (13) and membrane (5), and replace if defective ↪ 8.3 "Dismantling".

## 8.3 Dismantling

Personnel:

- Mechanic
- + additional qualification explosion protection

Protective equipment:

- Eye protection
- Protective workwear
- Protective gloves
- Safety boots

Requirements:

- Regulator has been purged ↪ 6.2 "Rinsing".
- Regulator has been disassembled ↪ 10.2 "Disassembly".

You must dismantle the regulator to be able to perform maintenance work and to replace components. The requirement is a clean working place in a workshop.

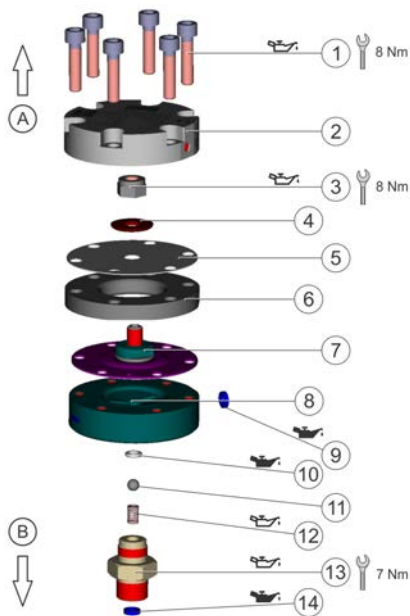

4. Loosen cheese-head screws with a hexagon socket (1).
5. Remove housing lid (2).
6. Loosen nut (3).
  - Hold membrane package (7) with a hexagonal socket.
  - Loosen nut (3) with an open-end wrench.
7. Mark the top side of the membrane (5).
8. Remove spacer (4), membrane (5), spacer ring (6) and membrane package (7).
9. Remove regulator from the vise. Clamp it again with the material side (B) facing upwards.
10. Loosen the custom nipple (13).
11. Remove spring (12), ball (11), O-ring (10) and sealing rings (9, 14).
12. Clean and check all components. Replace, if damaged. Replace seals.

Fig. 4: Exploded view

Molykote TP-42

Klüber Syntheso GLEP 1

1. Remove sealing ring (9) from regulator housing (8).
2. Clamp the regulator with the control side (A) upward into a vise.

Use protective jaws.

3. Mark housing with a line.

Use line as reference at assembly. This will ensure all connections are aligned correctly.

## 8.4 Assembly



Lubricate threads and seals before assembly.

Personnel:

- Mechanic
- + additional qualification explosion protection

Protective equipment:

- Protective workwear
- Eye protection
- Protective gloves
- Safety boots

1. Clamp regulator housing (8) with the material side (B) upwards into a vise.



Use protective jaws.

2. Lightly grease the new O-ring (10). Insert into the regulator housing (8).
3. Insert ball (11) into the regulator housing (8).
4. Lightly grease spring (12). Insert into the custom fitting (13).
5. Screw custom fitting (13) onto the regulator housing (8).
  - Tightening torque: 7Nm
6. Remove regulator from the vise. Clamp it again with the control side (B) facing up.



### NOTICE!

If the alignment is wrong, the membrane will be damaged.

For the assembly of the regulator, it is recommended to use the auxiliary tool (material number W02020048) 12.3 "Accessories".

Place membrane package (7) onto the auxiliary tool.

8. Put on the spacer ring (6).
9. Check membrane (5) for damage. Replace if necessary.



If the membrane is not replaced, assembly the membrane again with the marking upward. The membrane has been stretched out on one side during operation.

10. Put on the top membrane (5).

- 11.



### NOTICE!

If the alignment is wrong, the membrane will be damaged.

Place the spacer (4) with the rounded side facing down onto the membrane package (7).

12. Screw the nut (3) onto the membrane package (7).
  - Tightening torque: 8Nm
  - Hold membrane package (7) with a hexagonal socket.
  - Tighten the nut (3) with an open-end wrench.
13. Remove the auxiliary tool.



### NOTICE!

Particles on the membrane damage it.

14. Place the pre-assembled assembly onto the regulator housing (8).
15. Place housing lid (2) onto the top membrane (5).

16. Tighten the cheese-head screws (1) in a crosswise sequence.
  - Tightening torque: 8Nm
17. Lightly grease sealing ring (9). Insert into the regulator housing (8).
18. Lightly grease sealing ring (14). Insert into the custom fitting (13).

 Test the tightness and proper operation prior to recommissioning.

## 9 Faults

### 9.1 Defects table

For troubleshooting you have to (partly) dismantle the regulator ↪ 8.3 “Dismantling”. If faults cannot be remedied: ↪ “Hotline and Contact”.

Fault description	Cause	Remedy
Poor regulation	Ball, O-ring or compression spring are worn out	Replace ball, O-ring and compression spring.
	Membrane damaged	Replace membrane.
	Metal membrane chuck is damaged	<ul style="list-style-type: none"> <li>▪ Replace the membrane chuck.</li> <li>▪ Check membrane for damage.</li> <li>▪ If membrane is damaged, replace membrane.</li> </ul>
	Compression spring broken	Replace compression spring.
	Air supply fluctuates.	Check air regulation. Repair if necessary.
Air leaks from the leakage connection or between housing and lid	Membrane damaged	Replace membrane.
	Scoring in lid or spacer ring	Replace lid or spacer ring.
Material leaks from housing	Membrane damaged	Replace membrane.
	Spacer incorrectly assembled	Reassemble spacer.
	Cheese-head screws tightened with incorrect torque	Tighten cheese-head screws with the correct torque.
Whistling sound from regulator.	Regulator set incorrectly	<ul style="list-style-type: none"> <li>▪ Checking pressure settings.</li> <li>▪ Change parameters.</li> </ul>

## 10 Disassembly and Disposal

### 10.1 Safety recommendations



#### **WARNING!**

##### **Risk of injury due to escaping material and compressed air**

Escaping compressed material can cause serious injury.

Before carrying out any work:

- Disconnect the system, in which the regulator is installed, from compressed air and material supply.
- Secure the system against being switched on again.
- Depressurize the lines.



#### **WARNING!**

##### **Unsuitable tools in explosive areas**

Tools that do not have Ex approval can generate sparks and cause a fire or an explosion in Ex zones. It can cause serious injuries or death.

- If possible, carry out cleaning and maintenance work outside the Ex zones.
- For work within the Ex zone, use tools with the corresponding Ex labeling.



#### **WARNING!**

##### **Danger from harmful or irritant substances**

Serious injuries or death can result if you come into contact with dangerous fluids or steam.

- Regulator Check regularly for leakage. Observe local regulations and maintenance schedule.
- Ensure that the forced ventilation is operational.
- Follow the safety data sheet.
- Wear specified protective clothing.
- Avoid contact (e.g. with eyes, skin).

### 10.2 Disassembly

Personnel:

- Mechanic
- + additional qualification explosion protection

Protective equipment:

- Protective workwear
- Eye protection
- Protective gloves
- Safety boots

1. Rinse regulator ↪ 6.2 "Rinsing".
2. Close material supply line with valve and secure against being switched on again.
3. Depressurize the line ↪ 6.3 "Relieving pressure".
4. Loosen cap nut of material supply line.
5. Loosen cap nut of material discharge line.
6. Unscrew transparent hose from leakage connection.

7. Unscrew control air line from connection for control air.
8. Remove the regulator.

### 10.3 Disposal



#### ENVIRONMENT!

##### Improper waste disposal

Improper waste disposal threatens the environment and prevents re-use and recycling.

- Clean components before their disposal.
- Always dispose of components in accordance with their characteristics.  
↳ 11.8 “Materials used”
- Collect leaked out utilities and auxiliaries completely.
- Dispose of work equipment soaked in coating materials or operating substances according to the disposal provisions in force.
- Dispose of utilities and auxiliaries according to the disposal provisions in force.
- In case of doubt, refer to the local disposal authorities.

## 11 Technical data

### 11.1 Dimensions and weight

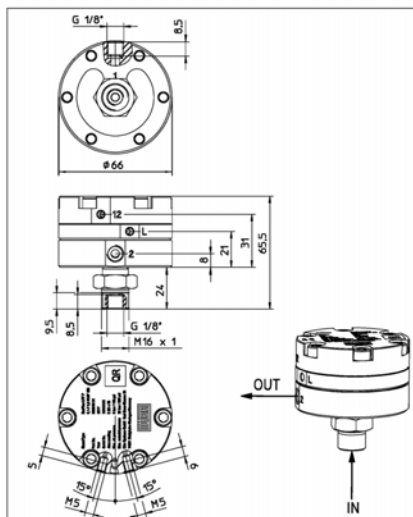

Fig. 5: Dimensions

Detail	Value
Total length	65.5mm
Diameter	66mm
Weight	0.66kg

### 11.2 Connections

Connection	Value
Material outlet	G1/8"
Material inlet	G1/8"
Control air	M5
Leakage line	M5

## Technical data

### 11.3 Operating conditions

Detail	Value
Operating temperature, min.	15°C
Operating temperature, max.	35°C
Ambient temperature, min.	15°C
Ambient temperature, max.	40°C

### 11.4 Emissions

Detail	Value
Noise	An imperfectly set regulator can emit whistling sounds.

### 11.5 Operating values

Detail	Value
Control air pressure, min.	1bar
Control air pressure, max.	8bar
Media input pressure, max.	20 bar
Control range	1 to 6.5bar
Flow rate, max.	2.5L/min

### 11.6 Compressed air quality

- Purity classes following ISO 8573-1:2010 1:3:1 1:4:1
- Limitations for purity class 4 (pressure dew point max.):
  - ≤ -3°C at 7bar absolute
  - ≤ +1°C at 9bar absolute
  - ≤ +3°C at 11bar absolute

### 11.7 Type plate

The type plate is also on the housing lid and features the following data:

- Product name
- Material number
- Year of manufacture
- Serial number
- Ex labeling
- Maximum air pressure
- Maximum material pressure
- Manufacturer
- CE labeling
- QR Code

### 11.8 Materials used

Component	Material
Lid, spacer ring	Aluminum
Regulator housing	Stainless steel
Parts in contact with material	Stainless steel
Membrane	PTFE
Ball	Hard metal

### 11.9 Operating and auxiliary materials

Material	Specification
Screw connections lubricant	Molykote TP-42
Seal lubricant	Klüber Syntheso GLEP 1

## 11.10 Material specification

Suitable Material:

- Flammable fluid coating materials of the explosion group IIA and their approved cleaning agents
- Non-flammable fluid coating materials and their approved detergents

Specification:

- Vapor pressure  $\leq 0.5$ bar above atmosphere
- Ignition temperature  $> 50^{\circ}\text{C}$
- Temperature  $\leq 35^{\circ}\text{C}$ , always 15K below flashpoint

## Viscosity

Detail	Value
Viscosity, min.	10mPa S
Viscosity, max.	250mPa S

## 12 Replacement parts, tools and accessories

### 12.1 Replacement parts

Item numbers relate to the  8.3 "Dismantling".

Item	Denomination	Quantity	Order No.
1	Cheese-head screw M6x25 DIN912 1.4301	6	included in KIT N26960005
2	Housing cover	1	-
3	Hexagonal nut M8 DIN985 1.4571	1	included in KIT N26960005
4	Spacer	1	included in KIT N26960005
5	Membrane	1	included in KIT N26960005
6	Spacer ring	1	-
7	Membrane package	1	M08500003
8	Regulator housing	1	-
9, 14	Sealing ring	1	included in KIT N26960005
10	O-ring 5.28x1.78	2	included in KIT N26960005
11	Ball D6 hard metal	1	included in KIT N26960005



Item	Denomination	Quantity	Order No.
12	Compression spring	1	included in KIT N26960005
13	Custom fitting	1	-

## 12.2 Tools



Fig. 6: Assembly tool

Designation	Quantity	Material no.
Assembly tool	1	W02020048

## 12.3 Accessories



Fig. 7: Accessories

Item	Description	Quantity	Material No.
1	Angle bracket 85x60x50	1	M19100396
2	Angle bracket 120x60x50	1	M19100397
3	Hexagonal nut M16x1 SA 358	1	M30030010

## 12.4 Order



### WARNING!

#### Unsuitable replacement parts in explosive areas

Replacement parts not compliant with the specifications of the ATEX guidelines can cause explosions in an explosive atmosphere. Serious injury and death could be the consequence.

- Use exclusively original replacement parts.



### WARNING!

#### Unsuitable replacement parts

Replacement parts of third-party suppliers may possibly not be able to hold the loads. Serious injury and death could be the consequence.

- Use exclusively original replacement parts.

Ordering replacement parts, tools and accessories as well as information on products that are listed without order number ↪ “Hotline and Contact”.





LEADING IN  
PRODUCTION  
EFFICIENCY

 Dürr Systems AG  
Application Technology  
Carl-Benz-Str. 34  
74321 Bietigheim-Bissingen  
Germany

 Phone +49 7142 78-0

 [www.durr.com](http://www.durr.com)

Translation of the original operation manual  
MRE00004EN, V04

The reproduction and distribution of this document, use and communication of its contents are not permitted without express written approval. Offenders will be liable for damages. All rights in the event of a patent grant or design registration are reserved.

© Dürr Systems AG 2016