

Pumps

Pump solutions for any kind of application



Product families

EcoPump HP - air operated horizontal piston pumps

EcoPump HPE - electrical operated horizontal piston pumps

EcoPump VP - air operated vertical piston pumps **EcoPump VPS** - air operated vertical shovel plate pumps **EcoPump AD** - air operated diaphragm pumps **EcoPump9 GW** - gear wheel dosing pumps

EcoPump Packages - ready to use sets

EcoPump AD

Air operated diaphragm pumps

A wide choice of materials for the pump housing makes the **EcoPump AD** the best solution for different kinds of fluid handling such as abrasive and particle containing fluids. The typical field of application of the **EcoPump AD** is to handle oil, water, waste liquids with and without solid particle debris, water and solvent-borne paints, varnishes, enamels and lacquers. The **EcoPump AD** pump will operate in circulation or direct fluid delivery mode. The simple design of **EcoPump AD** allows easy maintenance and service.



Watch product video

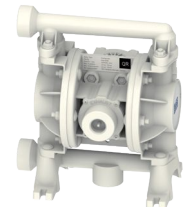

PRODUCT LINE

	EcoPump AD 150 21 SST 3/8"	EcoPump AD 150 21 SST 3/8"	EcoPump AD 72 8 ACE 1/4"	EcoPump AD 83 6,9 ACE 3/8"
Part No.	N24140013	N24140014	N24140005	N24140006
Weight	19.8 kg	19.8 kg	1.6 kg	1.9 kg
Connector inlet / outlet	G3/8" / G3/4" (female)	G3/8" / G3/4" (female)	G1/4" (female)	G3/8" (female)
Connector air	G1/4" (female)	G1/4" (female)	1/4" NPT (female)	1/4" NPT (female)
Displacement	150 cc/cycle	150 cc/cycle	72 cc/cycle	83 cc/cycle
Ratio	3:1	3:1	1:1	1:1
Max. fluid pressure	21 bar (305 psi)	21 bar (305 psi)	8.6 bar (125 psi)	6.9 bar (100 psi)
Flow rate max.*	3.0 l/min (0.78 gal/min)	3.0 l/min (0.78 gal/min)	6.5 l/min (1.7 gal/min)	13 l/min (3.4 gal/min)
Parts contacted by media	Stainless steel, POM	Stainless steel, PTFE	Acetal, PTFE	Acetal, PTFE

* strongly dependent on the material



	EcoPump AD 150 6,9 SST 1/2"	EcoPump AD 150 7 ACE 1/2"	EcoPump AD 150 7 ALU 1/2"
Part No.	N24140007	N24140008	N24140009
Weight	6.6 kg	4.0 kg	3.8 kg
Connector inlet / outlet	G1/2" (female)	1/2" NPT (female)	G1/2" (female)
Connector air	1/4" NPT (female)	1/4" NPT (female)	1/4" NPT (female)
Displacement	150 cc/cycle	150 cc/cycle	150 cc/cycle
Ratio	1:1	1:1	1:1
Max. fluid pressure	6.9 bar (100 psi)	6.9 bar (100 psi)	6.9 bar (100 psi)
Flow rate max.*	16 l/min (4.2 gal/min)	16 l/min (4.2 gal/min)	16 l/min (4.2 gal/min)
Parts contacted by media	Stainless steel, PTFE	Acetal, PTFE	Stainless steel, Al, PTFE

* strongly dependent on the material

EcoPump AD

Air operated diaphragm pumps



PRODUCT LINE

	EcoPump AD 600 8 SST 1"	EcoPump AD 600 8 ALU 1"	EcoPump AD 2420 8 SST 1 1/2"
Part No.	N24140004	N24140010	N24140011
Weight	16.3 kg	8.6 kg	38.3 kg
Connector inlet / outlet	G1" (female)	G1" (female)	G1½" (female)
Connector air	1/4" NPT (female)	1/4" NPT (female)	1/2" NPT (female)
Displacement	600 cc/cycle	600 cc/cycle	2,420 cc/cycle
Ratio	1:1	1:1	1:1
Max. fluid pressure	8.3 bar (120 psi)	8.3 bar (120 psi)	8.3 bar (120 psi)
Flow rate max. *	44 l/min (11.6 gal/min)	44 l/min (11.6 gal/min)	113 l/min (29.8 gal/min)
Parts contacted by media	Stainless steel, PTFE	Stainless steel, Al, PTFE	Stainless steel, PTFE

* strongly dependent on the material

CUSTOMER BENEFITS



Selected choice of materials for housing

Easy maintenance and service
Highly flushable

Suitable for abrasive fluids and media containing solids

TECHNICAL ILLUSTRATION

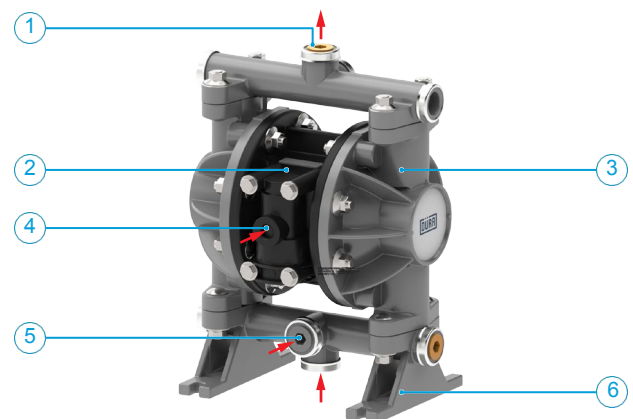

1 Material outlet, 2 Pneumatic part, 3 Fluid part, 4 Air inlet, 5 Material inlet, 6 Mounting feet