

# Pumps

Pump solutions for any kind of application



## Product families

**EcoPump HP** - air operated horizontal piston pumps

**EcoPump HPE** - electrical operated horizontal piston pumps

**EcoPump VP** - air operated vertical piston pumps **EcoPump VPS** - air operated vertical shovel plate pumps **EcoPump AD** - air operated diaphragm pumps **EcoPump9 GW** - gear wheel dosing pumps

**EcoPump Packages** - ready to use sets

# EcoPump HPE

## Electrical operated horizontal piston pumps

The **EcoPump HPE** is a horizontal piston pump with an electric drive to achieve superior performance with lower operating costs. It has been manufactured according to Dürr's well-proven quality standards. Durability and reliability are further distinguishing characteristics in order to meet the highest demands. With a concealed shaft seal the **EcoPump HPE** is primarily designed for paint circulation systems as well as fluid transfer and supply. A horizontal two piston design guarantees equal thrust on both strokes. Its modular design enables easy maintenance. Typically handled fluids include water and solvent-borne paints, varnishes, enamels and lacquers. The **EcoPump HPE** has been tested according to DIN EN 12162.



PRODUCT LINE			
	EcoPump HPE 400 21	EcoPump HPE 800 21	EcoPump HPE 1600 21
Part No.	N24260021	N24260022	N24260023
Weight	158 kg	188 kg	340 kg
Connector inlet / outlet	EcoTube DN25 (male) *	EcoTube DN25 (male) *	EcoTube DN25 (male) *
Displacement	400 cc/cycle	800 cc/cycle	1,600 cc/cycle
Parts contacted by media	Stainless steel	Stainless steel	Stainless steel
Max. fluid pressure	21 bar (305 psi)	21 bar (305 psi)	21 bar (305 psi)
Flow rate @ rec. cycles	8 l/min (2.1 gal/m) **	16 l/min (4.2 gal/m) **	32 l/min (8.4 gal/m) **
Rated power	0.75 kW	1.50 kW	3.00 kW

\* Sanitary type fluid ports are available as an option. \*\* Cycles for continuous operation and partial load.

### TECHNICAL ILLUSTRATION

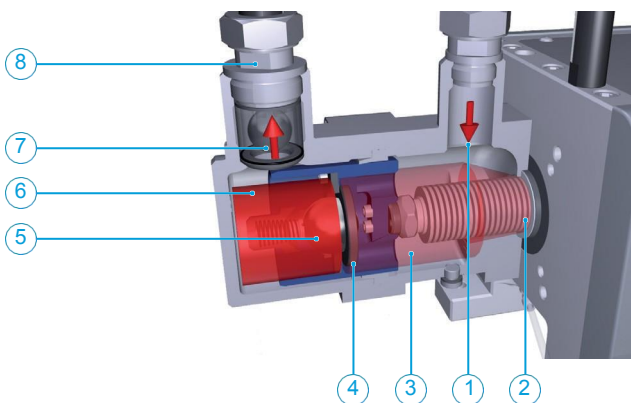

#### HP & HPE pump principle

1 Material inlet, 2 Bellows, 3 Material suction chamber, 4 Piston, 5 Piston ball seat, 6 Material outlet chamber, 7 Material outlet ball seat, 8 Material outlet

### CUSTOMER BENEFITS



Tested according to DIN EN 12162 and well-proven Dürr quality standards

Electrical drive provides superior performance with lower operating costs  
Stainless steel fluid sections

Four-ball design

No exposed shaft seal

Lubricant free

Horizontal two-piston design guarantees equal thrust on both strokes

Modular pump design, easy to maintain

ATEX Ex II 2G Ex h IIA T4 Gb X

# EcoPump HPE

## Electrical operated horizontal piston pumps

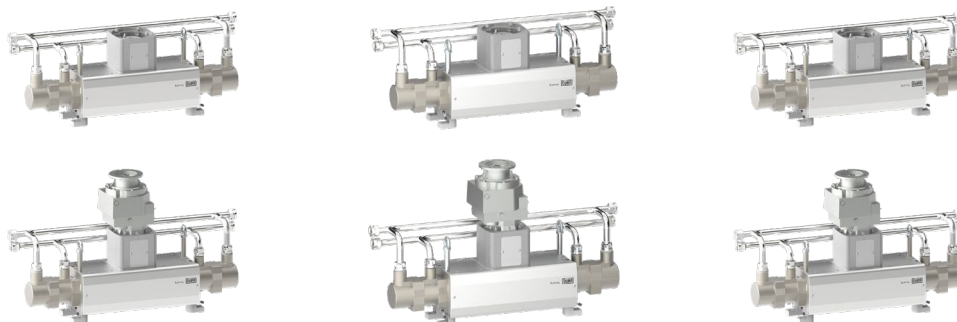

PRODUCT LINE			
	EcoPump HPE 400 21 US EcoPump HPE 400 21 UHM PTF KR EcoPump HPE 400 21 UHM PTF JP	EcoPump HPE 800 21 US EcoPump HPE 800 21 UHM PTF KR EcoPump HPE 800 21 UHM PTF JP	EcoPump HPE 1600 21 UHM PTF US EcoPump HPE 1600 21 UHM PTF KR EcoPump HPE 1600 21 UHM PTF JP
Part No.	N24260005 (w/o motor and gear box) N24260014 (w/o motor) N24260017 (w/o motor)	N24260006 (w/o motor and gear box) N24260015 (w/o motor) N24260018 (w/o motor)	N24260007 (w/o motor and gear box) N24260016 (w/o motor) N24260019 (w/o motor)
Weight	154 kg	186 kg	370 kg
Connector inlet / outlet	EcoTube DN25 (male) *	EcoTube DN25 (male) *	EcoTube DN25 (male) *
Displacement	400 cc/cycle	800 cc/cycle	1,600 cc/cycle
Parts contacted by media	Stainless steel	Stainless steel	Stainless steel
Max. fluid pressure	21 bar (305 psi)	21 bar (305 psi)	21 bar (305 psi)
Flow rate @ rec. cycles	8 l/min (2.1 gal/m) **	16 l/min (4.2 gal/m) **	32 l/min (8.4 gal/m) **
Rated power	1.12 kW	1.50 kW	3.7 kW

\* Sanitary type fluid ports are available as an option. \*\* Cycles for continuous operation and partial load.