

Pumps

Pump solutions for any kind of application



Product families

EcoPump HP - air operated horizontal piston pumps

EcoPump HPE - electrical operated horizontal piston pumps

EcoPump VP - air operated vertical piston pumps **EcoPump VPS** - air operated vertical shovel plate pumps **EcoPump AD** - air operated diaphragm pumps **EcoPump9 GW** - gear wheel dosing pumps

EcoPump Packages - ready to use sets

EcoPump HP

Air operated horizontal piston pumps

The **EcoPump HP** is an air driven horizontal piston pump. It has been manufactured and tested according to Dürr's well-proven quality standards. Performance and durability are further distinguishing characteristics in order to meet the highest demands. With a concealed shaft seal this **EcoPump HP** is primarily designed for paint circulation systems as well as fluid transfer and supply. A horizontal two piston design guarantees equal thrust on both strokes and a rapid pump change-over with a quick release valve for reduced surge. Its modular design enables easy maintenance. Typically handled fluids are water and solvent-borne paints, varnishes, enamels and lacquers.



PRODUCT LINE			
	EcoPump HP 400 21	EcoPump HP 800 21	EcoPump HP 1600 21
Part No.	N24160008	N24160009	N24160010
Weight	45.0 kg	54.4 kg	94.0 kg
Connector inlet / outlet	EcoTube DN25 (female) *	EcoTube DN25 (female) *	EcoTube DN25 (female)*
Connector air	G3/8" (female)	G3/8" (female)	G3/4" (female)
Displacement	400 cc/cycle	800 cc/cycle	1,600 cc/cycle
Ratio	3.5:1	3.5:1	3.5:1
Max. fluid pressure	21 bar (305 psi)	21 bar (305 psi)	21 bar (305 psi)
Flow rate @ rec. cycles	8 l/min (2.1 gal/m)	16 l/min (4.2 gal/m)	32 l/min (8.5 gal/m)
Recommended cycles	20 cyc/min **	20 cyc/min **	20 cyc/min **
Max. air pressure	6.0 bar (87 psi)	6.0 bar (87 psi)	6.0 bar (87 psi)

* Sanitary type fluid ports are available as an option. ** Cycles for continuous operation and partial load.

TECHNICAL ILLUSTRATION

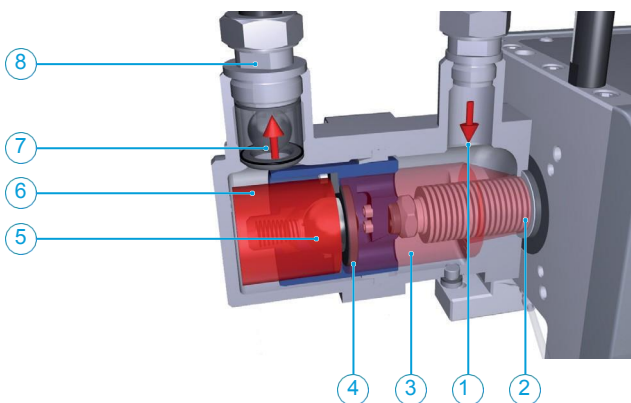

HP & HPE pump principle
 1 Material inlet, 2 Bellows, 3 Material suction chamber, 4 Piston, 5 Piston ball seat, 6 Material outlet chamber, 7 Material outlet ball seat, 8 Material outlet

CUSTOMER BENEFITS

- Balanced pressure variations
- Stainless steel fluid section

- Tested according to DIN EN 12162 and well-proven Dürr quality standards
- low icing by thermal isolation of the muffler and optimized air flow

- Four-ball design
- No exposed shaft seal

- tubricant free

- Horizontal two-piston design guarantees equal thrust on both strokes

- Rapid pump change-over with quick release valve for reduced surge

- Modular pump design, easy to maintain

- Wide range of accessories available